



ARAPAHOE COUNTY

GESC MANUAL



September 2025

Previous Revisions:

February 2023

May 2019

May 2018

December 2010

(Resolution No. 100036)

Adopted:
January 2005

Grading, Erosion and Sediment Control Manual

Table of Contents

1	THE GESC PROGRAM	4
1.1	INTERPRETATION AND APPLICATION.....	7
1.2	AMENDMENTS AND REVISIONS.....	7
1.3	STATE AND FEDERAL PERMITTING.....	7
1.4	ENFORCEMENT RESPONSIBILITY	8
1.5	SPECIAL CONSIDERATIONS FOR CO-REGULATING MS4 PERMITTEES	8
1.6	DELEGATION OF AUTHORITY TO SEMSWA	9
2	GESC PROGRAM CONSIDERATIONS.....	9
2.1	WHEN A PERMIT IS REQUIRED	9
2.2	A GESC PLAN IS NOT A SWMP	10
2.3	GESC PROGRAM PERMIT RESPONSIBILITY.....	10
2.4	REVIEW AND APPROVAL LIMITATIONS.....	10
2.5	GESC PLAN AMENDMENT PROTOCOLS.....	11
2.6	WATER CONTROL PLAN REVIEW	11
2.7	VARIANCES TO THE GESC MANUAL	11
3	TYPES OF PERMITS	13
3.1	GRADING, EROSION, AND SEDIMENT CONTROL (GESC) PERMIT	14
3.2	EROSION AND SEDIMENT CONTROL (ESC) PERMIT	16
3.3	LOW RISK GUIDANCE PROCESS PROTOCOLS.....	17
4	GESC OR ESC PERMIT REQUIREMENTS.....	18
4.1	GESC OR ESC PERMIT ADMINISTRATION.....	18
4.2	PERMITTEE(S) RESPONSIBILITIES	25
4.3	INSPECTIONS.....	27
5	ENFORCEMENT.....	30
5.1	NONCOMPLIANCE	31
5.2	RIGHT TO COMPLETE GESC CONTROL MEASURES AND USE OF FUNDS.....	32
	GESC or ESC	32
6	FIELD POLICIES.....	32
6.1	LIMITS OF CONSTRUCTION	32
6.2	STREET CLEANING.....	32
6.3	DUST CONTROL	33
6.4	CONSTRUCTION SITE WASTE CONTROL	33

6.5	ADMINISTRATIVE CONTROLS	33
6.6	POTENTIAL POLLUTANTS AT A CONSTRUCTION SITE	34
6.7	EQUIPMENT MAINTENANCE.....	34
6.8	SPILL AND LEAK CONTROL.....	34
6.9	TEMPORARY AND FINAL STABILIZATION METHODS.....	35
7	SITE GRADING DESIGN GUIDANCE AND CRITERIA	36
7.1	TOPSOIL MANAGEMENT	36
7.2	SLOPES	39
7.3	STOCKPILES ASSOCIATED WITH GESC PERMITS.....	39
8	DESIGN, INSTALLATION, AND MAINTENANCE OF CONTROL MEASURES	40
8.1	CUT BACK CURB (CBC)	40
8.2	CHECK DAM (CD).....	41
8.3	CONCRETE WASHOUT AREA (CWA) and GROUT WASHOUT AREA (GWA).....	42
8.4	CONSTRUCTION FENCE (CF)/CONSTRUCTION MARKERS (CM).....	42
8.5	STORMWATER DEWATERING (DW).....	42
8.6	DIVERSION DITCH (DD).....	44
8.7	EROSION CONTROL BLANKET (ECB).....	45
8.8	GROUT MIXING STATIONS (GMS)	47
8.9	INLET PROTECTION (IP).....	47
8.10	REINFORCED ROCK BERM (RRB) or REINFORCED ROCK BERM FOR CULVERT PROTECTION (RRC).....	48
8.11	SEDIMENT BASIN (SB)	48
8.12	SEDIMENT CONTROL LOG (SCL).....	51
8.13	SEDIMENT TRAP (ST).....	51
8.14	SEEDING AND MULCHING (SM)	52
8.15	SILT FENCE (SF).....	52
8.16	SLOPE INTERCEPT DITCH (SID)	53
8.17	STABILIZED STAGING AREA (SSA)	53
8.18	STREET SWEEPING (SS).....	54
8.19	SURFACE ROUGHENING (SR)	54
8.20	TEMPORARY SLOPE DRAIN (TSD).....	54
8.21	TEMPORARY STREAM CROSSING (TSC)	55
8.22	VEHICLE TRACKING CONTROL (VTC).....	57
8.23	VEHICLE TRACKING CONTROL WITH WHEEL WASH (WW)	57
9	DEFINITIONS	57
	Appendices.....	64

Appendix A–GESC Program Permitting Matrix.....	64
Appendix D–GESC Plan Checklist.....	67
Appendix E–GESC Narrative Template	68
Appendix F–GESC or ESC Standard Notes and Details.....	69
Appendix G–Engineer’s Cost Estimate	70
Appendix H–Erosion and Sediment Control Permit Plan Template	71
Appendix I–Low Risk Guidance.....	72
Appendix J–Hold Harmless Letter for Early Start of Grading.....	73
Appendix K–Single-Family Residential Lot Erosion Control Certificate	74

1 THE GESC PROGRAM

This *Grading, Erosion and Sediment Control Manual (GESC Manual)* describes the [GESC program](#) adopted by Arapahoe County (County) to promote environmentally sound construction practices during [construction activities](#). Arapahoe County and the Southeast Metro Stormwater Authority (SEMSWA) are partners in implementing the GESC program. SEMSWA is the County’s authorized agent to administer the GESC program. The GESC Manual is authorized and approved by the Arapahoe County Board of County Commissioners (BOCC), originally adopted on February 22, 2005 and subsequently amended from time to time.

The GESC program is the regulatory framework established by the County to comply with the requirements set by the construction sites program of the County’s [municipal separate storm sewer \(MS4\)](#) permit. The [grading, erosion, and sediment control \(GESC\) permit](#) program shall apply to the County standard permit area, hereafter referred to as “standard permit area”, and outside of the standard permit are on a case-by-case basis. A map of the County’s standard permit area is available on the County’s ArapaMap (<https://gis.arapahoe.gov/ArapaMAP/>). For those areas of the County outside of the permit area zoned A-E or A-1 east of Watkins Road, grading, erosion, and sediment control requirements are established in Chapter 4 of the County *Rural Engineering Standards*.

GESC permits will be issued by either SEMSWA or the County depending on the location of the project. In general, SEMSWA will implement the GESC Manual within the County permit area within the SEMSWA service area. SEMSWA will implement the GESC Manual outside of the County permit area within the SEMSWA service area on a case by case basis. The County will implement the GESC Manual within the County’s MS4 permit area outside of the SEMSWA Service Area. The County will implement the GESC Manual outside of the permit area and outside of the SEMSWA Service area on a case by case basis. Please see Figure 1 for a map of the County’s MS4 permit area and SEMSWA’s service area.

The goal of the GESC permit program is to implement effective construction [control measures](#) (formerly known as best management practices) as a standard for applicable [land disturbing activities](#) to [minimize](#) the discharge of pollutants associated with construction activities. During the relatively short period of time when undeveloped land is converted to urban uses or developed land

is redeveloped, a significant amount of sediment can erode from a construction site and be transported to adjacent properties and receiving waters. Erosion caused by land disturbing activities, and the resulting downstream sedimentation, can damage property and degrade the quality of streams and lakes. Sediment is a transport mechanism for many [stormwater](#) pollutants. Eroded sediment can impact riparian and aquatic habitat and, since eroded sediments often contain significant amounts of phosphorus, this can lead to unwanted algae growth in lakes and reservoirs. The County and SEMSWA are committed to protecting water resources and ensuring that future development continues in an environmentally sound manner.

The County's permit area also includes the Cherry Creek Reservoir Watershed area. The [Cherry Creek Reservoir Control Regulation No. 72](#) (CR 72) identifies specific requirements for erosion and sediment control measures on construction sites within the [Cherry Creek Reservoir Watershed](#) draining into

Figure 1: Map of the County' MS4 Permit area and SEMSWA's Service Area. Please see <https://gis.arapahoegov.com/ArapaMAP/> for the most current map.

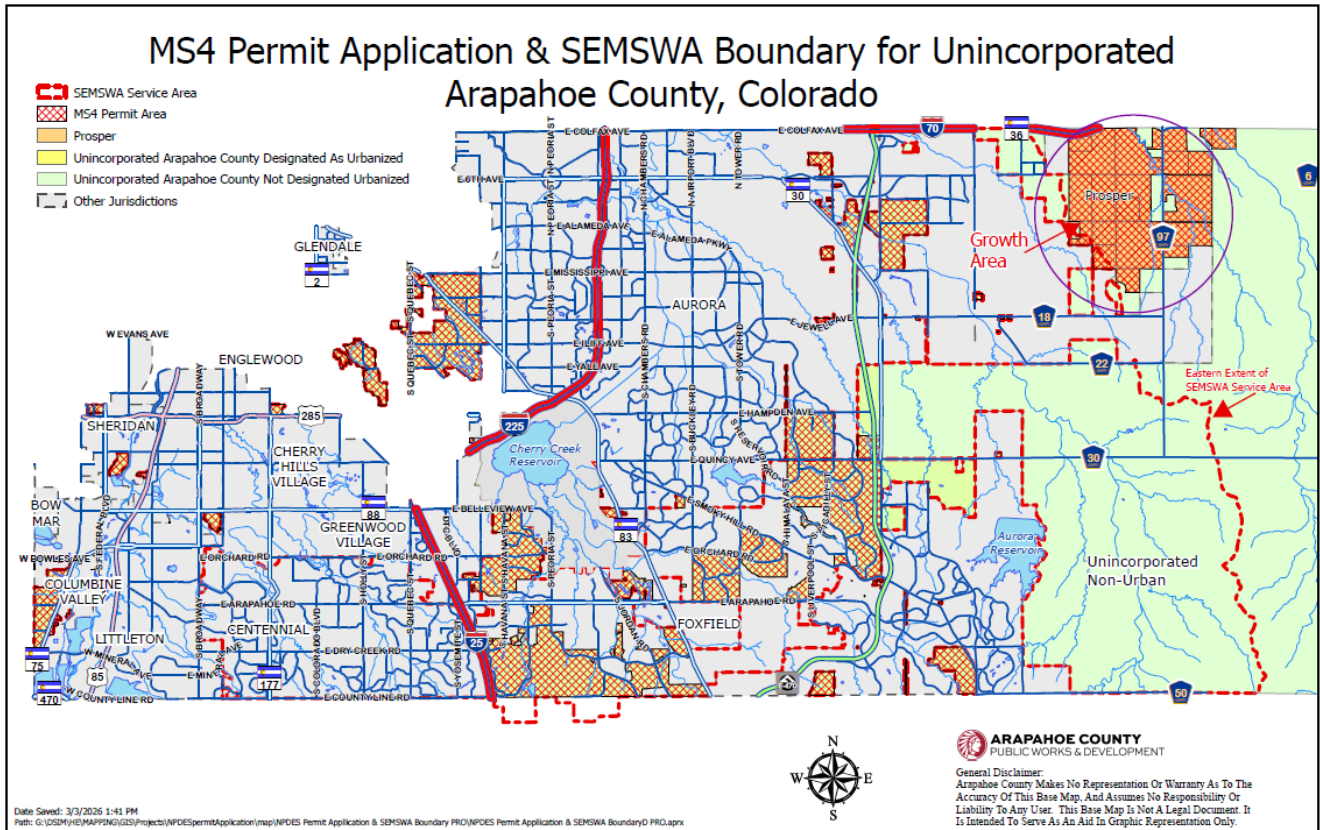

the Cherry Creek Reservoir. The Control Regulation places limits on the area of land that can be disturbed at any one time. The intent of the regulation is to protect the water quality of the Cherry Creek Reservoir.

1.1 INTERPRETATION AND APPLICATION

In the interpretation and application of the provisions of the GESC Manual, the following shall govern: These provisions shall be regarded as the minimum requirements for the protection of public health, safety, and welfare. The GESC Manual shall, therefore, be regarded as remedial and shall be liberally construed to further its underlying purposes.

Whenever a provision in these criteria or any provision in any law, ordinance, resolution, rule or regulation of any kind, contain restrictions covering the same subject matter, whichever is more restrictive or imposes higher standards shall govern. If there is a discrepancy in the interpretation of the GESC Manual, the County Technical Review Committee (TRC) shall make the final determination of the intent of the GESC Manual. Appeals to the TRC shall follow the process outlined in [Section 2.7](#) of this Manual.

If a special district or other government entity with jurisdiction at the site imposes more stringent criteria, such differences are not considered conflicts. When differences arise, the more stringent requirements shall apply. If Federal or State law imposes stricter criteria, standards or requirements on the County through MS4, or other state or federal permits, such shall be incorporated into these requirements after proper notice and public hearing(s) needed to modify the GESC Manual.

A GESC permit, an [erosion and sediment control \(ESC\) permit](#), or a low risk guidance process is required prior to the start of any construction activities within the County’s permit area in accordance with the GESC Program Permitting Matrix in Appendix A.

The GESC Manual shall not abrogate or annul any permits or approved drainage reports or construction plans issued before the effective date of this GESC Manual.

1.2 AMENDMENTS AND REVISIONS

These policies and criteria may be amended and revised as new technology is developed and experience is gained. The BOCC, following the recommendations of the Public Works and Development Director (herein referred to as “Director”), may consider such amendments and revisions. Minor revisions, such as correction of typos or errors, that do not change any policy adopted in this Manual, may be amended with prior notice to the Board of County Commissioners.

1.3 STATE AND FEDERAL PERMITTING

The State of Colorado and some Federal agencies require separate, additional permits for some construction-related activities that are included as part of the GESC program. [Applicants](#) are responsible for contacting the Colorado Department of Public Health and Environment-Water Quality Control Division (CDPHE-WQCD); Federal Emergency Management Agency (FEMA); and/or the US Army Corps of Engineers (Corps) for specific permitting information for a project.

Information on some of the permits that may be applicable are included in the sections below. This is not to be considered a comprehensive list.

1.3.1 STATE PERMITTING

Applicants are responsible for complying with all applicable state permits and requirements. In compliance with the Colorado Discharge Permit System (CDPS) the State requires that construction projects equal to or greater than 1 acre of disturbance, or less than 1 acre of disturbance if part of a larger [common plan of development or sale](#) that is 1 acre or more, must obtain a Stormwater Construction Permit (SCP) and develop a Stormwater Management Plan (SWMP). It should be noted that a GESC plan is not a SWMP (see [Section 2.2](#)).

In addition, the WQCD has several [dewatering general permits](#). The permits establish water quality standards and control measures for dewatering discharges. Additional permitting from the State Engineer's Office may be required if it is determined that there is a consumptive water use or loss.

In addition, air quality permits from the State may also be required.

1.3.2 FEDERAL PERMITTING

Applicants are also responsible for complying with all applicable federal permits and requirements. This may include, but is not limited to, the Federal Emergency Management Agency (FEMA) map revision process, the United States Army Corps of Engineers (Corps) Section 404 permit, and the United States Fish and Wildlife Service, Endangered Species Act Section 10 and/or Section 7 permits. Applicants are advised to confirm the Federal requirements that may apply.

Projects that impact the regulatory floodplain may need to obtain a Conditional Letter of Map Revision (CLOMR) and/or Letter of Map Revision (LOMR) from FEMA.

Excavation activity associated with a dredge and/or fill project in Waters of the United States (including streams, open water lakes, ponds, wetlands, etc.) may require a Section 404 permit and/or other permitting.

1.4 ENFORCEMENT RESPONSIBILITY

The BOCC, acting through the authority of the Director of Public Works and Development and its designee(s), shall enforce the provisions of the GESC Manual.

1.5 SPECIAL CONSIDERATIONS FOR CO-REGULATING MS4 PERMITTEES

To facilitate project permitting and the inspection process, and to avoid the need for duplicative plan review, approval, and permit issuance, the County may relinquish control of construction site program requirements to an adjacent MS4 permittee's Program if there is an agreement in place with the entity and a portion of the construction activity is within that MS4 permittee's area. The County may also accept control of construction site program requirements from an adjacent MS4 permittee if there is an agreement in place with the entity, and a portion of the construction activity is within the County's MS4 permit area. The MS4 permittee may assume full jurisdictional control for construction site stormwater runoff control activities, including plan review and approval, permit issuance, and inspections for the entire project, including those areas in the permit area, only when a site-specific

agreement between the entity and the County exists. Enforcement remains the responsibility of the permittee where the construction activity is occurring, and should be included in the site-specific agreement.

1.6 DELEGATION OF AUTHORITY TO SEMSWA

The County has delegated authority to SEMSWA within their service area to implement the provisions of this manual, except Appendix K (Single Family Residential Lot Erosion Control Certificate). Within their service area, SEMSWA is authorized to perform all functions and responsibilities otherwise reserved to the County herein with the exception of prosecution of violations. SEMSWA enforcement activity will be guided by the terms of the Memorandum of Understanding (2008) between the County and SEMSWA, and the Standard Operating Procedures incorporated therein. Where County officials or bodies are assigned duties, obligations, or roles herein, then when applied to the authority delegated to SEMSWA, such duties, obligations, or roles shall be that of the SEMSWA official or body with the functionally equivalent role as that of the County official or body.

2 GESC PROGRAM CONSIDERATIONS

Within the SEMSWA service area, the County has delegated authority to SEMSWA to administer and implement the provisions of this chapter in accordance with Section 1.6.

The GESC program was developed to ensure adequate design, implementation, maintenance and enforcement of control measures for stormwater quality management to prevent or minimize stormwater pollution from construction activities.

Construction activity refers to ground surface disturbing and associated activities (land disturbance) such as, but not limited to, clearing, grading, excavation, demolition, installation of new or improved haul roads and access roads, staging areas, stockpiling of fill materials, and borrow areas. Construction activity does not include [routine maintenance](#) to maintain the original line and grade, hydraulic capacity, or original purpose of the facility. Activities to conduct repairs that are not part of regular maintenance or for replacement are construction activities and are not routine maintenance. Repaving activities where underlying and/or surrounding soil is cleared, graded, or excavated as part of the repaving operation are considered construction activities unless excluded in the County's MS4 permit. Construction activity is from initial groundbreaking to [final stabilization](#) regardless of ownership of the construction activity. Several administrative considerations have been included in this section to clarify the permit process.

2.1 WHEN A PERMIT IS REQUIRED

The GESC program includes the [grading erosion, and sediment control \(GESC\) permit](#), the erosion and sediment control (ESC) permit, and the [low risk construction activity](#) guidance process, as further discussed in Section 3 and collectively referred to as the "GESC program permits". GESC program permits are required for projects meeting the GESC Program Permitting Matrix criteria, available in Appendix A, for projects within the permit area. A GESC program permit is required prior to the start of any land-disturbing activities within the permit area. Construction activities that result in a land disturbance of greater than or equal to 1 acre or that is less than 1 acre, but is part of a larger common plan of development or sale that disturbs one acre or more, shall be permitted unless otherwise excluded below. Additionally, any project that the County Public Works Director, or designee,

determines to have an adverse impact on the public right-of-way, public infrastructure, or adjacent property, with respect to grading, erosion, and sediment control will be required to obtain a GESC Determination of which GESC program permit to obtain can be found in [Section 3](#) “Types of GESC Permits” and in the GESC Program Permitting Matrix Criteria in [Appendix A](#).

The following construction activities are not subject to the requirements of the GESC Manual:

- County approved CDPHE-WQCD waived requirements for stormwater discharges associated with a small construction activity in accordance with Regulation 61.3(2)(f)(ii)(B) (the “R-Factor” waiver).
- Projects that are otherwise exempted by law outside of the County’s purview, such as some agricultural activities.

2.2 A GESC PLAN IS NOT A SWMP

For sites disturbing 1 acre or more, or less than 1 acre of disturbance if part of a larger common plan of development or sale that disturbs 1 acre or more, the [permittee\(s\)](#) is responsible for complying with the CDPS Stormwater Construction permit issued by CDPHE-WQCD. The CDPS-Stormwater Construction permit requires a SWMP that is typically prepared by the contractor and not submitted for review by the County. The GESC plan and SWMP requirements are not the same, as they are implemented for two different permits. It is the responsibility of the applicant to comply with any CDPS Stormwater Construction permit requirements that are applicable to their site, including the development of a SWMP. The SWMP cannot be submitted to meet GESC requirements but can be used to assist with GESC submittal which must meet the requirements outlined in [Section 3.1](#).

2.3 GESC PROGRAM PERMIT RESPONSIBILITY

GESC and ESC permits shall be signed by both the [owner](#) and the [operator](#). Prior to the issuance of the applicable permit, the owner and the operator are referred to as “applicants.” After the permit is issued, both are considered the “permittee(s)” and must comply with the applicable GESC program permit requirements. Changes to the owner or operator will require a new GESC or ESC permit to be issued in accordance with [Section 4.1.3](#). The specific contractual relationship between the owner and operator as the permittee(s) must allow for immediate correction of deficiencies. The permittee(s) shall be legally responsible for compliance with the permit. If the applicant is not an individual, an [authorized agent](#) of the entity must sign the permit on behalf of the permittee(s). Designation of the authorized agent must accompany the permit submittal.

Permittee(s)/[responsible party](#) conducting construction activities are responsible for meeting all requirements of the GESC Manual, including installing and maintaining all control measures in the approved GESC plan. Failure to meet these requirements may lead to enforcement action (See [Section 5](#), Enforcement).

2.4 REVIEW AND APPROVAL LIMITATIONS

The GESC program submittals will be reviewed for compliance with the criteria contained herein. The acceptance of submitted documents by the County does not relieve the applicant or design engineer

of responsibility for ensuring that calculations, plans, specifications, and construction comply with the criteria contained herein or from complying with all other applicable Federal, State, or local laws or regulations.

2.5 GESC PLAN AMENDMENT PROTOCOLS

Minor plan modifications may be allowed only with the County’s written approval. The permittee(s) must update the GESC or ESC plan as necessary to reflect site conditions. All [minor modifications](#) shall be implemented immediately and recorded on the plan. It is expected that the permittee(s) will need to make minor GESC modifications throughout a project to address changes in site conditions. Minor modifications generally include modifications that do not increase the scope or change hydrology of the site, but modify/improve specific control measures in use at a site, and include control measure substitutions for other measures that are equivalent in performance and/or are more suitable to specific site conditions, relocation of previously approved control measures within the [limits of construction](#), or changes to control measures based on the phasing of the site. For the purpose of this section, scope is defined as modifications that include design components.

Major plan modifications are those involving re-engineering or changes to site hydrology and are not considered a Minor plan modification. These modifications must be submitted to the County for review and acceptance. Changes to control measures that may be classified as a [major modification](#) are indicated with a “box” surrounding the control measure acronym, as indicated in the GESC or ESC Plan- Standard Notes and Details.

Major or minor modifications that are not in conformance with the GESC Manual are required to go through a variance process in accordance with [Section 2.7](#).

2.6 WATER CONTROL PLAN REVIEW

Where a construction project includes stream or conveyance channel crossings or improvements with active water flow, the GESC review process includes consideration of a Water Control Plan to identify the phasing of work necessary to meet controls required in Waters of the United States and/or [waters of the state](#) to meet Federal, State, and/or local laws and regulations. The water control plan must be prepared for the County’s review at or prior to the Preconstruction Meeting as a condition of [GESC permit](#) issuance. The County’s review will determine potential impacts to County GESC permitted activities and if major or minor modifications to the GESC plan are required ([Section 2.5](#)) as a result of implementing the water control plan. The County does not review the water control plan for compliance with state or federal requirements.

2.7 VARIANCES TO THE GESC MANUAL

No variance to the GESC program requirements as contained in the GESC Manual will be considered that would result in a noncompliance with the County’s MS4 permit. Outlined below is the process of submitting a variance request and appealing a denied request for a variance from these standards. All GESC program variance requests will be submitted to the County initially for a technical analysis of the potential impact on stormwater discharges and determination of compliance with the MS4 permit requirements.

2.7.1 VARIANCE CRITERIA

Variance requests must be submitted with documentation evidencing all the approval criteria are met. The approval criteria are as follows:

- The variance represents the smallest degree of deviation necessary from the applicable standard;
- The variance will not cause property damage to upstream or downstream properties;
- The variance will not impose undue adverse environmental impacts;
- The variance will not compromise access to the property and safe traffic flow;
- The variance will not compromise the public health, safety, and welfare; and
- The variance will not result in an MS4 permit violation.

A variance shall be granted only upon the finding that the approval criteria have been satisfied. In ruling upon a variance, the County shall also consider the impacts the proposed variance would have on construction and maintenance requirements and cost.

2.7.2 VARIANCE AND APPEAL PROCEDURES

Submittal Requirements. The applicant must submit a written request for a variance. At a minimum, the variance request must include the following information:

1. Identification of the GESC Manual criteria sought to be waived or varied;
2. Identification and detailed description of the alternative to the GESC Manual criteria; and
3. Justification of, and reason for, the variance request; and
4. Justification that variance criteria in [Section 2.7.1](#) have been met.

When the submittal requirements have been adequately addressed the application is complete and the variance submittal will then be processed pursuant to this section. The applicant will be notified by the County if the variance submittal is deemed incomplete. No further processing of an incomplete request shall occur until the deficiencies are corrected.

Variances are intended to occur during the plan review process and prior to GESC or ESC plan approval. Rarely, a variance is requested after a GESC or ESC permit is issued. In such cases the variance must be reviewed and approved prior to field implementation. The County's written approval of a variance must be issued before the variance can be implemented. Unapproved variances are considered noncompliant and enforcement can occur in accordance with Section 5, Enforcement.

Review by the Technical Review Committee (TRC). Complete applications shall be considered by Technical Review Committee at the next regularly scheduled TRC meeting. The applicant shall be informed of the meeting date and may attend to provide additional evidence on its behalf. The TRC shall act to approve, approve with conditions, or deny the variance request based on the approval criteria set forth herein. The TRC shall render a written decision within five (5) working days following the meeting at which the variance was considered.

Appeal of the TRC's Decision. The applicant may appeal a denial of a variance request to the TRC within thirty (30) days of the date of TRC's written denial. The applicant's appeal shall be submitted in writing to the TRC. The applicant shall be informed of the meeting date and may attend to provide additional evidence on its behalf. The TRC shall act to approve, approve with conditions, or deny the variance request based on the approval criteria set forth herein. The TRC shall render a written decision within five (5) working days following the meeting at which the variance was considered.

Appeal of the TRC's Appeal Decision. The applicant may appeal a denial of a variance request to the Director of the Department of Public Works and Development within thirty (30) days of the date of the TRC's written denial. The applicant's appeal shall be submitted in writing to the Director. Within ten (10) working days of receipt of the applicant's written notice of appeal, the Director shall consider the variance request de novo and render a decision to uphold or reject the TRC's decision on the variance request based on the approval criteria set forth herein.

Final Appeal to Board of County Commissioners. An applicant may appeal the Director's decision to the Board within 30 days of the date of the Director's written denial. The applicant's appeal shall be submitted in writing to the Board of County Commissioners and will schedule a public hearing to review the applicant's appeal within 60 days. The Board will review the Director's decision for clear error based on the record before the Director and issue a decision within 30 days of the public hearing.

2.7.3 BURDEN OF PROOF

The applicant bears the [burden of proof](#) that the approval criteria has been met.

3 TYPES OF PERMITS

Within the SEMSWA service area, the County has delegated authority to SEMSWA to administer and implement the provisions of this chapter in accordance with Section 1.6.

The GESC Manual allows for the following types of permits and process to be used:

- [Grading, Erosion, and Sediment Control \(GESC\) Permit.](#)
- ESC Permit.
- [Low Risk Guidance Process.](#)

3.1 GRADING, EROSION, AND SEDIMENT CONTROL (GESC) PERMIT

A GESC permit is required for construction activities that result in a land disturbance of greater than or equal to 1 acre or that is less than 1 acre, but is part of a part of a larger common plan of development or sale that disturbs 1 acre or more. These projects may have multiple owners, or after development by one owner, will contain multiple lots that can be sold to a new owner(s).

Certain construction activities with a land disturbance less than 1 acre and not part of a larger common plan of development or sale can result in sedimentation of the stormwater system or contribute to a water quality violation, as determined by the County. Such activities may include adverse impacts to drainage patterns, adjacent properties, floodplain and waterways, or other [environmentally sensitive areas](#). These construction activities may require a GESC permit even though the disturbance is less than 1 acre and not part of a larger common plan of development or sale that disturbs one acre or more.

GESC permits are required for utility construction (Appendix B) oil and gas construction (Appendix C) activities in unincorporated Arapahoe County outside of the SEMSWA service area.

3.1.1 PLAN REQUIREMENTS

The following requirements shall be adhered to when preparing a GESC plan. The GESC plan typically includes three plan sheets to show control measures for the initial, interim and final phases of construction. The GESC plan shall locate and identify all [structural](#) and [non-structural control measures](#) for the applicable construction activity, as necessary. Further, the GESC plan shall meet the requirements contained in the GESC Checklist located in Appendix D and shall be completed and submitted with the GESC plan to ensure that each requirement is addressed. The approved GESC plan shall also be consistent with the approved Drainage plan for the site.

Control measures as shown in the GESC plan must:

1. Prevent pollution or degradation of state waters.
2. Be appropriate for the specific construction activity, the applicable pollutant sources, and phase of construction. Control measures must be selected, designed, installed, implemented, and maintained in accordance with [good engineering, hydrologic, and pollution control practices](#).
3. Be implemented prior to the start of construction activity for the applicable phase, must control potential pollutants during each phase of construction, and must be continued through final stabilization. Appropriate structural control measures must be maintained in operational conditions.
4. Be selected, designed, installed, implemented, and maintained to provide control of all potential pollutants, such as but not limited to sediment, construction site waste, trash, discarded building materials, concrete truck washout, chemicals, sanitary waste, and contaminated soils in discharges to the MS4.

The GESC plan shall be signed and stamped by the engineer in responsible charge, or the engineer. The calculations necessary for a GESC plan shall be prepared by or under the responsible charge of, and signed and stamped by a professional engineer registered in the State of Colorado. (See statutory requirements in § 12-25-101, et seq., C.R.S.). The following are the components of a GESC plan:

3.1.1.1 Cover Sheet

All GESC submittals are stand-alone documents independent of other site civil construction drawings. Therefore, a separate cover sheet is required.

3.1.1.2 Initial Control Measures

This plan sheet shall provide control measures for the initial clearing, grubbing and preparation of a project. This sheet can be combined with the interim GESC control measures sheet if both stages of control measures can be illustrated sufficiently for the [operator](#) to understand the timing of installation. Consolidating sheets shall be approved by the County prior to submittal for review.

3.1.1.3 Interim Control Measures

This plan sheet shows control measures for the grading, site construction, and site re-vegetation process. These control measures shall be based on proposed grades and drainage features.

3.1.1.4 Final Control Measures

This plan sheet shows control measures at completion of site construction through the final stabilization phase. This sheet can be combined with the initial and interim GESC control measures sheet if all stages of control measures can be illustrated sufficiently for the operator to understand the timing of installation. Consolidating sheets shall be approved by the County prior to submittal for review.

3.1.1.5 Narrative Sheet

A project-specific narrative template shall be completed and included in the GESC Plan (GESC Narrative Template Appendix E). The narrative sheet replaces a GESC report.

3.1.1.6 GESC or ESC Plan- Standard Notes and Details

A copy of the GESC or ESC Plan—Standard Notes and Details (Appendix F) shall be provided with the GESC or ESC plan.

3.1.2 REQUIREMENTS FOR STAGED AND PHASED GESC PLANS

To reduce the potential for soil exposure to runoff events and the potential for erosion, actively disturbed areas within the GESC plan are limited to 40 acres or less at a time. Exceeding the 40-acre limit may be allowed when the applicant can demonstrate through a variance process that the 40-acre limit is physically and/or financially

impracticable. For sites granted this exceedance, a phasing and earthwork quantities plan shall be submitted to the County and, following adequate review, approved by the County prior to the commencement of land disturbance activities. Submittal requirements include: (I) Phasing Plan showing cut and fill volumes and locations for each Phase and project totals; (II) Earthwork Quantity Plan showing cut and fill volumes for each phase and project totals; and (III) Erosion Control Plan showing specific erosion and sediment controls for each phase. Phased and staged plans for actively disturbed areas greater than 40 acres must meet the stabilization requirements in [Section 6.9](#).

3.1.3 FEES AND COLLATERAL

permit fees shall be paid in accordance with the current applicable fee schedule. [Collateral](#) shall be submitted, based on the control measures required for site control ([Section 4.1.1](#)) and in accordance with the [Engineer's Cost Estimate](#) (Appendix G).

3.2 EROSION AND SEDIMENT CONTROL (ESC) PERMIT

Some construction activities with less than 1 acre of disturbance and not part of a larger common plan of development or sale that disturbs 1 acre or more may have only a minor to moderate potential impact on downstream receiving waters. These projects do not adversely impact drainage patterns, adjacent properties, floodplain and waterways, or other environmentally sensitive areas, which can result in sedimentation of the stormwater system or contribute to a water quality violation. The determination of whether a project qualifies for an ESC permit shall be at the sole discretion of the County.

ESC sites have a lower level of complexity such that control measures can be presented adequately in a simple sketch plan developed with or without the assistance of an engineer. The County can be contacted for an ESC plan consultation. Erosion and Sediment Control permitted sites are less than 1 acre of disturbance and not part of a larger common plan of development or sale that disturbs one acre or more, but meet one or more of the following conditions:

- Construction activity associated with new development and redevelopment (limited to scrape and reconstruct) as part of a land use review process, including commercial, industrial and residential but not including individual single-family residential construction unless otherwise specified in this section.
- Projects that include the construction of a post-construction water quality control measure.
- Projects that include the construction of public stormwater improvements.
- Construction activities that disturb the floodplain and require a County No-Impact Floodplain Development permit.
- Linear transportation projects that do not otherwise qualify for a GESC permit in [Section 3.1](#) or meet the low risk protocols outlined in [Section 3.3](#).
- Utility projects outside of the County right-of-way that do not otherwise qualify for a GESC permit or meet the low risk protocols.

3.2.1 PLAN REQUIREMENTS

For ESC plans that require a Land Use process, the plans must be signed and stamped by the engineer. For all other ESC plan submittals, the plans are not required to be prepared or stamped by the engineer and shall utilize the ESC Permit Plan Template (Appendix H). ESC plans shall be prepared and submitted to the County and must include the following:

- All surface water hydrologic features that may affect work area, including run-on drainage.
- Location of control measures to minimize pollution to the state waters from the construction activity.
- Implementation control measures for all phases of construction through final stabilization.
- Attached GESC or ESC Plan- Standard Notes and Details. Only notes italicized within the standard notes are applicable to the ESC permit.
- Justification that the disturbance is less than 1 acre and not part of a larger common plan of development or sale that disturbs one acre or more.

3.2.2 FEES AND COLLATERAL

Permit fees shall be paid in accordance with the applicable fee schedule and collateral shall be submitted in accordance with the Engineer's Cost Estimate in Appendix G.

3.3 LOW RISK GUIDANCE PROCESS PROTOCOLS

Some minor land disturbing activities, less than 1 acre and not part of a larger common plan of development or sale that disturbs one acre or more, are not anticipated to contribute sediment to the stormwater system. These projects have a low potential of causing a water quality impact and/or a violation of a water quality standard and are identified as "low risk." The GESC permit program does not allow a low risk designation for construction activities that have the potential to adversely impact drainage patterns or result in sedimentation of the stormwater system. To be considered low risk, construction activities must meet the following conditions:

1. Land disturbance less than 1 acre, not part of a larger common plan of development or sale that would disturb one acre or more.
2. Does not qualify for an ESC or GESC permit.
3. Does not result in a post-construction water quality requirement.
4. The discharge must be visibly clear and not contain floating or solid materials.
5. Does not result in an impact to the floodplain.
6. Does not require any other County permits, except for a No-Impact Floodplain Development, or an Annual Floodplain Development permit.

7. Is not expected to contribute sediment to the stormwater system and has a low potential of causing a water quality impact and/or a violation of a water quality standard.
8. Produces negligible soil loss or movement.
9. Complies with the lawful requirements of federal agencies, municipalities, counties, drainage districts, ditch owners, and other local agencies regarding any discharges to storm drain systems, conveyances, ditches or other water courses under their jurisdiction.
10. Does not result in an adverse impact on adjacent properties and/or flooding of neighboring property, streets, gutters or storm sewers.
11. Access for inspections can occur from the right-of-way.
12. Does not adversely impact drainage patterns.

The GESC program allows low risk sites to be managed without a formal permit if there is adherence to control measure(s) specified for the activity described in Appendix I. Failure to comply with the control measures established for the low risk designated activity could result in the County requiring a GESC or ESC permit to be obtained and/or enforcement under the County's Illicit Discharge Detection and Elimination (IDDE) program.

For low risk sites within the Cherry Creek Basin, the County fact sheet will suffice as an erosion and sediment control plan, describing approved and appropriate control measures for the type of low risk activity. The County shall approve the use of the low risk fact sheet documents as meeting CR 72 requirements for these sites or projects.

4 GESC OR ESC PERMIT REQUIREMENTS

Within the SEMSWA service area, the County has delegated authority to SEMSWA to administer and implement the provisions of this chapter in accordance with Section 1.6.

4.1 GESC OR ESC PERMIT ADMINISTRATION

4.1.1 APPROVED GESC OR ESC PLAN

GESC and ESC plans must be submitted and approved by the County. GESC and ESC plans are subject to rereview for criteria and fee changes if plans are resubmitted more than 90 days after the original County approval. [Applicants](#) will be notified when the GESC or ESC Plan has been stamped. GSC and ESC plans are considered valid for 2 years following their approval.

The GESC or ESC plan shall be consistent with other approved plans such as the construction drawings. The GESC or ESC plan shall be submitted along with other related County plans and permit applications. The applicant may be required to obtain other permits as part of the project to facilitate development, including Building permits, Land Use approvals, Street Cut Right-of-Way Use permits, Public Improvement permits, and Floodplain Development permits. These other related plans and permits may not reflect all requirements for development in the County. The applicant should verify plans and permits required from the County specific to their development.

4.1.2 GESC or ESC PERMIT EXPIRATION

A GESC or ESC permit issued by the County expires 2 years after issuance. At the County's discretion, the permits may be administratively extended upon good cause shown and upon notice to the permittee. Any permit that has been administratively extended and is subsequently found to be noncompliant with the GESC Program may be revoked by the County, provided the permittee is given adequate notice and an opportunity to reapply for a permit. GESC or ESC permits may be revoked in accordance with [Section 5](#). Additional permit fees may be assessed in accordance with the fee schedule.

4.1.3 GESC PERMITS WITH OWNERSHIP OR OPERATOR CHANGES

Multi-lot development typically involves the transfer of ownership of portions of the GESC permitted area during the life of the project, and they include common areas, which may serve or be impacted by multiple owners. It is important that control measures be in place to ensure that the GESC program requirements are maintained on all portions of the original development throughout the life of the project. Prior to any transfer of ownership, existing owners are responsible for ensuring control measures are installed and maintained in accordance with the GESC plan and [Section 4.2](#) and that temporary or final stabilization has occurred, as necessary, in accordance with [Section 6.9](#). New owners are responsible for obtaining a GESC permit for any disturbed areas and should reference the GESC Permit Program Matrix in Appendix A to determine the GESC permit and GESC plans required, including applicable fees.

When a discrete portion of a development project is sold, the new owner shall be required to obtain a permit for that portion of the property or project. The County must be notified when a change in ownership occurs on a GESC permitted project. An existing GESC plan for the property or project may provide the necessary control measure requirements, as determined by the County. If an existing GESC plan does not provide the necessary control measure requirements, the new owner may be required to provide a new GESC plan, [GESC permit](#), and collateral in accordance with the GESC program requirements. This includes when a GESC permitted site is sold from a developer to a new entity. The developer must ensure the common areas are still appropriately permitted since they serve the entire site. These include the streets and rights-of-way, the common open space areas, drainage tracts and easements, stormwater detention and water quality facilities, and other areas that are not associated with the individual lots that are now in new ownership. Such areas need to be accounted for in an agreement between permittee(s).

If a different owner/operator replaces the previous owner/operator that is identified on the GESC permit, a new GESC permit is required to reflect the new owner/operator and includes the payment of permit fee. Failure to obtain a [GESC permit](#), pay permit fees, and/or provide collateral for the new responsible owner/operator or permittee(s) may result in enforcement.

4.1.4 RESPONSIBILITIES FOR SINGLE-FAMILY RESIDENTIAL PROJECTS WITHIN MASTER DEVELOPED SUBDIVISIONS

This section applies to master developed subdivisions with a GESC permit and are associated with single family home construction activity that is part of a larger common plan of development of sale. When individual lots are sold from a permittee(s) to a homeowner, the individual lot may be removed from the County's GESC inspections if the following requirements are met and have been documented:

- The lot has less than one acre of disturbance.
- The construction activity associated with grading the lot and building the home is completed.
- A certificate of occupancy or equivalent has been issued to the homeowner.
- The project must have a GESC plan and still be inspected by the permittee(s.)
- The permittee(s) has notified the County in writing that the lot has been sold to a homeowner.
- The County has approved the documentation outlined above from the permittee(s).

Upon change of ownership from the permittee(s) to the homeowner, the homeowner shall be responsible for final stabilization of the lot and for the control measures on the property until final stabilization is achieved. The GESC program requires through its regulations that homeowners prevent the erosion and transport of sediment from their property. Homeowners are required to provide permanent stabilization of their lot, through such measures as sod, established seeded vegetation, rock, landscaping or other permanent measures of stabilization per applicable Land Development Code. The transport of sediment from a homeowner lot into the MS4 may be enforced as an [illicit discharge](#).

4.1.5 REVIEW FEE PAYMENT

Review fees are submitted with the initial GESC or ESC submittal package. Review fees for a GESC or ESC plan are specified in the fee schedule.

4.1.6 EARLY GRADING PERMIT REQUIREMENTS

Early grading is limited to only grading activities for less than 40 acres and does not include the installation of permanent impervious area or the installation of utilities. Early grading requests should include consideration of the timeline necessary to avoid delaying construction activities pending the acceptance of remaining documents and permits and meeting the conditions below.

To obtain the approval to perform early grading on a site where development approvals are imminent but before having approved construction documents, the following conditions must be met.

- Favorable recommendation from the Planning Commission, or if the project is not heard by a Planning Commission, approval by the Board of County Commissioners. If the project requires only administrative County approval, the County must otherwise approve of the early grading. In all cases the applicant must have the ability to obtain any applicable County permits necessary for Early Grading.
- GESC or ESC plan complete and approved by the County.
- Applicant signed and submitted [Hold Harmless Letter for Early Start of Grading](#) (Appendix J).
- Applicant ability to obtain applicable County permits necessary for the Early Grading, including permit fees and collateral, as applicable. If work is to be completed within the floodplain, a Floodplain Development permit, including the approval of the necessary documentation will be also required prior to the issuance of the early grading permit.
- A minimum of one County review of the construction documents, with sufficient detail, completed with no major comments remaining.
- A minimum of 60 days of grading prior to the installation of infrastructure including, but not limited to, utilities. If this cannot be achieved, the applicant may demonstrate that delaying grading would result in one or more of the following, as approved by the County:
 - Substantial operational hardship due to seasonal constraints (winter, habitat protections, seasonal groundwater concerns);
 - Critical project scheduling (timing for public improvements and private construction activities); or,
 - Existing site conditions (unsafe conditions, unstable soils, groundwater levels, environmental remediation).

4.1.7 EARLY GRADING PERMIT REQUIREMENTS SPECIFIC TO MASS GRADING ACTIVITIES

To obtain the approval to perform early grading on a site where significant earthwork activities are required, the following conditions must be met. Significant earthwork activities are limited to a minimum of 90 days of grading operations for import or export of soil on sites 40 acres or larger. Early grading is limited to only grading activities and does not include the installation of permanent impervious area or the installation of utilities.

- Favorable recommendation from the Planning Commission for the site zoning or a concept plan, or if the project is not heard by a Planning Commission, approval by the Board of County Commissioners. If the project requires only administrative County approval, the County must otherwise approve of the

construction documents. In all cases the applicant must have the ability to obtain any applicable County permits necessary for Early Grading.

- GESC or ESC plan complete and approved by the County.
- Mass grading drainage analysis complete and approved by the County.
- Applicant signed and submitted hold harmless letter for early start of grading.
- Applicant ability to obtain applicable County permits necessary for the Early Grading, including permit fees and collateral, as applicable. If work is to be completed within the floodplain, a floodplain development permit including the approval of the necessary documentation will be also required prior to the issuance of the early grading permit.

4.1.8 PERMIT FEE PAYMENT

Permit fees are to be paid prior to the GESC or ESC permit issuance. Permit fees are identified in the current fee schedule.

4.1.9 ENGINEER'S COST ESTIMATES

Applicants submitting a GESC plan are required to provide engineer's cost estimates (ECE) associated with implementing the initial, interim, and final stabilization control measures. A template for the two ECEs to be submitted is provided in Appendix G and provides unit cost information that shall be used to generate the cost estimate. The ECEs will quantify the collateral that will secure appropriate control measures. For projects that will be phased, the ECEs must be separated and sub-totaled for each phase of the project on the ECE calculation spreadsheets.

Applicants submitting an ESC plan shall utilize the standard ESC ECE shown in Appendix G.

4.1.10 COLLATERAL POSTING

Collateral may be collected based on the control measures required for site control during construction, and for site final stabilization. Table 4.1 lists the collateral requirements.

The conditions under which the GESC or ESC collateral is held separate from any other security relating to the project site's Public Improvement Agreement (PIA) or any other agreements or permits relating to the site. GESC or ESC collateral will be retained and released separately per the GESC Manual requirements.

4.1.10.1 AMOUNT OF COLLATERAL

The amount of collateral for a GESC permit is determined as shown in Table 4.1. A copy of the worksheets to be used for preparing the ECE for control measures during construction, and for the site's final stabilization.

If the land disturbance for a site is over 20 acres, or the development has multiple or complex phasing plans, an alternate approach to collateral may be considered, when coordinated with and approved by the County.

The collateral for an ESC permit is the amount shown on the ESC ECE included in Appendix G.

Table 4.1 SUMMARY OF COLLATERAL REQUIREMENTS

Permit Type or Process	Collateral Required	Amount
GESC	Yes	Higher of the initial, interim, or final ECE
ESC	Yes	Amount shown on the ECE or other County approved amount
Low Risk	No	None
Partner Government Agencies (including SEMSWA formation partners, jurisdictions, Water and Sanitation Districts, Fire Districts, Park and Rec Districts, and CDOT)	No	Executed written agreement addressing GESC or ESC requirements, control measure implementation and final stabilization
Government Agencies	Yes	10% of higher of the initial, interim, or final ECE or other agreed upon amount with executed written agreement addressing GESC or ESC requirements, control measure implementation and final stabilization

4.1.10.2 FORMS OF COLLATERAL

The County accepts two forms of collateral:

- Irrevocable letter of credit from a Colorado financial institution meeting the County’s standard template, or a form similar to the County’s standard template and language with minor, non-substantive changes, if approved by the County Attorney.
- Cash Escrow.

The conditions of each form of collateral shall allow the collateral to be held for a minimum of 3 years. The 3-year period should allow for completion of all GESC or ESC and other agreement requirements. GESC permit collateral shall also include two growing seasons as typical to allow time for re-vegetation to reach the required coverage for final stabilization and GESC permit close-out.

The County requires the use of a template for an irrevocable letter of credit, which can be found on the County’s web site.

4.1.10.3 EXPIRATION OF COLLATERAL

If the construction of the project or stabilization process takes longer than 3 years, the permittee(s) must extend the posted letter of credit for 1 year a minimum of 30 days prior to the expiration date. This extension must be requested by the permittee(s). Failure to extend the collateral, prior to the 30-day deadline on an active site, may result in enforcement and the County drawing upon the collateral to ensure permit conditions are met.

The permittee(s) shall maintain the collateral amount required for the GESC control measures in full force and effect until final close-out of the GESC or ESC permit.

4.1.10.4 RELEASE OF COLLATERAL

For GESC permits, if the final ECE control measures collateral amount is less than the initial/interim ECE amount, the permittee(s) may request a reduction in collateral after initial close-out has been granted by the County. The decision to reduce collateral at any time is at the County's discretion. The collateral for the project will be released once final close-out is issued for the GESC permit.

There is no reduction of collateral for ESC permits. The collateral for the project will be released once final close-out is issued for the ESC permit .

4.2 PERMITTEE(S) RESPONSIBILITIES

4.2.1 RESPONSIBILITIES OF THE GESC MANAGER

The permittee shall identify a [GESC manager](#) to be the contact person for the [grading, erosion, and sediment control inspector \(inspector\)](#) on all matters pertaining to the GESC plan and permit and shall respond to requests made by the inspector and have any deficiencies in the work corrected. The GESC manager may be an employee of the [owner](#) or operator and shall have the authority to act on behalf of the permittee(s), including committing funds, to ensure that the site remains in compliance with the [GESC permit](#). In all matters, the permittee(s) shall remain the legally responsible party.

The permittee(s) shall also select an alternate GESC manager who can serve in the same capacity as the GESC manager. The GESC manager shall ensure that the alternate GESC manager assumes the GESC manager's responsibilities during any absence. The GESC manager and alternate GESC manager shall be named at the onsite preconstruction meeting. The permittee shall notify the inspector in writing of any contact changes to the GESC manager or alternate GESC manager.

The GESC manager shall be on site as necessary to ensure the GESC plan and GESC permit requirements are being implemented and shall provide the inspector with contact information, including email and phone number. The contact information will ensure that the GESC manager can be contacted to provide adequate site status updates in a reasonable timeframe. In the event the GESC manager (or alternate GESC manager) cannot be reached within 24 hours, and the site is in a state of noncompliance, enforcement may occur.

4.2.2 DOCUMENT AVAILABILITY

A copy of the GESC or ESC plan and GESC or ESC permit must be provided upon request to the County within the timeframe specified in the request.

4.2.3 PRECONSTRUCTION MEETING, INSTALLATION OF INITIAL CONTROL MEASURES, AND INITIAL INSPECTION

Upon the County's signature and stamping of the GESC or ESC plan, the contractor shall install non-earth disturbing initial-stage control measures indicated on the approved GESC or ESC plan. An onsite preconstruction meeting, which also consists of an initial inspection, is required prior to GESC or ESC permit issuance. The applicant shall refer to the GESC or ESC Plan- Standard Notes and Details legend for initial control measures to be installed prior to the pre-construction meeting and initial inspection. Construction activity may commence after permit issuance following a passing initial inspection. Volume control measures, such as sediment basins, shall be installed as soon as feasible after permit issuance.

For GESC permits, the inspector and GESC manager are required to attend the preconstruction meeting. In addition, the following representatives should attend the preconstruction meeting: general contractor, owner, or owner's representative, operator, alternate GESC manager, grading subcontractor, and control measure contractor/inspector. The general contractor may not be the owner's representative.

If the inspector determines that modifications or corrections to the initial control measures are necessary at the preconstruction meeting, the inspector will inform the applicant that such corrections shall be made. If necessary, the initial inspection shall be rescheduled with the inspector.

Control measures must be installed, implemented, and maintained in accordance with good engineering, hydrologic and pollution control practices.

4.2.4 INSTALLATION OF INTERIM AND FINAL CONTROL MEASURES

It is the responsibility of the GESC permittee(s) to ensure that interim control measures and subsequent final control measures are installed at the earliest opportunity. Some control measures have specific time requirements for installation that are identified on the GESC or ESC Plan—Standard Notes and Details; these time requirements shall be adhered to.

For control measures where a specific time frame is not given, the controls shall be installed immediately, unless [infeasible](#), to minimize pollutants. In these cases, it is up to the discretion of the inspector to make the final determination of interim and final control measure installation timeframes. control measures must be installed, implemented, and maintained in accordance with good engineering, hydrologic and pollution control practices.

Immediately after construction in drainageways, or after removal of a temporary stream crossing, all disturbed areas shall be topsoiled; seeded and mulched; and, unless otherwise approved, protected with erosion control blanket.

4.3 INSPECTIONS

An inspection is a process of evaluating and assessing a construction site or facility to ensure compliance with the requirements and conditions outlined in the permit. It involves conducting a thorough examination of the site, control measures, pollutant sources, and discharge points to identify any illicit discharges, failure to implement control measures, [inadequate control measures](#), control measures requiring routine maintenance, or other non-compliance. Inspections may involve visual examination, documentation review, sampling, and interviews with relevant personnel. The purpose of inspections is to minimize or prevent pollution, ensure the proper implementation of control measures, and determine compliance with the GESC Manual. Inspections must be documented, and any necessary follow-up actions must be taken based on the inspection findings. The permittee(s) must update the GESC or ESC plan as necessary to reflect current site conditions. The inspection must assess:

Control measures: Identify failure to implement control measures, inadequate control measures, and control measures requiring routine maintenance.

Pollutant sources: Evaluate all pollutant sources, including trash, to determine if an illegal discharge has occurred.

Discharge points: Evaluate discharge points to the MS4, or beyond the limits of the construction site as necessary to determine if an offsite discharge of pollutants has occurred. The permittee(s) must remove the pollutants, when feasible, when a failure to implement a control measure or an Inadequate control measure resulting in pollutants discharging to the MS4 or beyond the limits of the construction site is identified.

4.3.1 INSPECTIONS CONDUCTED BY GESC OR ESC PERMITTEE(S)

During construction, control measures must be inspected regularly by the permittee(s) at a frequency to ensure that adequate control measures are installed, implemented, and maintained in accordance with good engineering, hydrologic and pollution control practices. The required permittee or responsible party inspections are in Table 4.2.

At a minimum, sites with a State Construction Stormwater General permit must have self-documented site inspections in compliance with the site's SWMP.

For areas within the [Cherry Creek Watershed](#) draining to the Cherry Creek Reservoir, the permittee(s) or responsible party must inspect control measures after installation of any construction control measure, after any runoff event, and at least every 14 days. For sites where construction activities are completed but final stabilization has not been achieved due to a vegetative cover that has been planted but has not become established, the permittee(s) or responsible party may reduce the inspection frequency to once every 30 days.

The permittee(s) or responsible party shall provide inspection reports to the inspector upon request, in the timeframe specified within the request.

Table 4.2 SUMMARY OF REQUIRED PERMITTEE(S)/RESPONSIBLE PARTY INSPECTIONS¹

Location	Risks Assessed	Inspection Requirements
Outside of the Cherry Creek Basin	GESC	Follow COR400000 inspection frequency requirements documented in SWMP
Outside of the Cherry Creek Basin	ESC	Every 14 days, and after precipitation events that cause surface erosion
Outside of the Cherry Creek Basin	Low Risk	As necessary, in accordance with the County’s low risk guidance document
Within the Cherry Creek Basin	GESC	Follow inspection frequency requirements in CR 72 and follow COR400000 inspection frequency requirements documented in SWMP
Within the Cherry Creek Basin	ESC	Follow inspection frequency requirements in CR 72
Within the Cherry Creek Basin	Low Risk	Follow inspection frequency requirements in CR 72

4.3.2 GESC Inspections Conducted by the County

For GESC or ESC permitted sites, control measures will be inspected regularly by the inspector. The inspector will consider the overall effectiveness of the controls and will generally check for proper installation and maintenance of the controls. It remains the responsibility of the permittee(s) or responsible party to ensure that the site remains in compliance with all GESC program requirements. The County’s typical inspections consist of the following inspection types as defined in the County’s MS4 permit or in [Section 4.3.2.1](#) or [4.3.2.2](#):

- Initial.
- Routine.
- Compliance.
- Indicator.
- Initial Close-Out.
- Reduced (Inactive Site).
- Final Close-Out.

4.3.2.1 INITIAL CLOSE-OUT INSPECTION

Initial close-out may be requested when all disturbed areas have implemented final stabilization in accordance with [Section 6.9](#) of the GESC Manual.

¹ This table is only a suggested frequency. Self-inspections must be conducted at a frequency to ensure that the site is in compliance with the GESC permit at all times

Prior to the initial close-out inspection, the following must be completed:

- All streets, sidewalks and flowlines must be cleaned and free of sediment or debris.
- Clean all inlets, trickle channels and all other drainage features, as necessary.
- Remove construction control measures (per the approved GESC or ESC plan) and install/maintain final stabilization control measures per the approved GESC or ESC plan.

Once all items are completed, the permittee(s) shall contact the County and schedule an initial close-out inspection. The initial close-out acceptance process may also be initiated by the County. In addition to the inspector, a representative of the permittee(s) shall attend the initial close-out inspection.

Any corrections noted during the initial close-out inspection shall be made to the site as requested by the inspector, and when completed, a re-inspection can be scheduled with the inspector.

Once the initial close-out inspection is approved by the County, the inspector shall grant initial close-out. Once initial close-out is granted, collateral may be reduced. See [Section 4.1.10.4](#) for potential collateral reduction.

4.3.2.2 FINAL CLOSE-OUT INSPECTION

Final close-out may be requested when construction is complete and all areas have been finally stabilized in accordance with [Section 6.9](#) of the GESC Manual. Prior to final close-out inspection the following must be done:

- The inspector has confirmed that vegetation has met the final stabilization requirements as defined in [Section 6.9](#).
- All streets, sidewalks and flowlines must be cleaned and free of sediment and/or debris.
- Clean all inlets, trickle channels and all other drainage features, as necessary.
- Remove all temporary control measures.
- Maintain all stormwater infrastructure, to include but not limited to post-construction control measures (such as grass swales and buffers, extended detention basins, and bioretention facilities), to ensure proper functionality of the stormwater system, as necessary.

During the final close-out inspection, the inspector will check the removal of temporary control measures, confirm final stabilization, and either accept the site as final, or stipulate the corrections that must be made.

Any corrections noted during the final close-out inspection shall be made as requested by the inspector, and when completed, a re-inspection can be scheduled with the inspector. Once the final close-out inspection is approved, the inspector shall grant final close-out, and release remaining collateral to the permittee(s).

For applicable site, a Single-Family Residential Lot Erosion Control Certificate (Appendix K) must be submitted to the County before a certificate of occupancy can be issued.

5 ENFORCEMENT

Within the SEMSWA service area, the County has delegated authority to SEMSWA to administer and implement the provisions of this chapter in accordance with Section 1.6.

Failure to comply with any term, condition, limit, deadline or other provision of the GESC program shall constitute a violation. This includes but is not limited to a failure to comply with the GESC or ESC permit, failure to obtain a GESC or ESC permit, or keep an updated GESC plan.

The County's *Enforcement Response Plan* (ERP) can be found on its web site. The County may, at its discretion, use any one or several of the following enforcement mechanisms, solely or collectively, in addition to any other legal or equitable remedies that the County may have for GESC violations:

- Education;
- Verbal warnings;
- Issuance of noncompliance fees;
- Withhold issuance or extensions of permits;
- Withhold inspections;
- Issuance of a Notice of Noncompliance, Preliminary Notice of Violation, or Notice of Violation;
- Issuance of a Stop Work Order;
- Revocation or suspension of the GESC permit;
- Use of collateral;
- Conduct abatement and collect restitution;
- Refuse to issue other necessary approvals until such violation has been corrected and the permittee(s) has taken the necessary action to ensure compliance with the GESC program requirements, and
- Judicial action.

5.1 NONCOMPLIANCE

A noncompliance occurs when the permittee(s) is not meeting the requirements of the GESC program, including the GESC or ESC plan and GESC or ESC permit. Remedies will be available to the County in accordance with the remedies contained herein, other legal or equitable remedies, and any resolution(s) or policies containing provisions for providing remedies for enforcement against defaults or violations. The following list identifies actions that constitute noncompliance; however, noncompliance actions are not limited to the list below. The County's ERP explains noncompliance, enforcement, and escalation procedures. The following are examples of noncompliant activities:

- Control measures not maintained in operational condition at time of a GESC or ESC inspection, including sites that have temporarily shut down construction activities;
- Uncorrected finding(s) from previous GESC or ESC inspections or failure to correct any noncompliance specified on any written notice of noncompliance within the timeframe specified;
- Failure to implement control measures in accordance with good engineering, hydrologic, and pollution control practices;
- Failure to implement a control measure for a pollutant source or inadequate control measure that may result in a discharge of pollutants from the limits of construction, the MS4, or a state water;
- Failure to obtain a GESC or ESC permit;
- Permittee(s) fails to construct the improvements in substantial compliance with the GESC or ESC plan and the other requirements of the GESC program;
- Permittee(s) otherwise breaches or fails to comply with any obligation of the GESC or ESC permit and/or GESC program not specifically identified herein;
- Permittee(s) become insolvent, files a voluntary petition of bankruptcy, is adjudicated as bankrupt pursuant to an involuntary petition in bankruptcy, or a receiver is appointed for the permittee(s) where these actions result in a noncompliance;
- Permittee(s) fails to maintain in full force and effect a letter of credit to secure collateral in the amounts specified in this Manual;
- Permittee(s) fails to remove temporary control measures when final stabilization has occurred;
- Failure to pay noncompliance fees in the timeframe specified; and/or
- Discharge of any pollutant, including sediment, outside of the limits of construction or to a state water.

Additional noncompliance actions may be determined at the discretion of the County based on an assessment of the action in relation to a violation of the GESC program.

5.2 RIGHT TO COMPLETE GESC CONTROL MEASURES AND USE OF FUNDS

The County shall have the right to complete or maintain control measures to correct any noncompliance with the GESC or ESC permit or GESC program. The County may assign its rights to complete, maintain, and correct noncompliance to a third party.

The County shall be entitled to make a draw on the letter of credit or cash collateral for the amount reasonably determined to be necessary to correct the default in a manner consistent with the GESC program and MS4 permit requirements up to the face amount of the letter of credit or cash collateral; and recover from the permittee any amount necessary to correct the default over and above the amount available under the letter of credit, or lien the property, including reasonable administrative costs and attorneys' fees.

6 GESC or ESC FIELD POLICIES

Within the SEMSWA service area, the County has delegated authority to SEMSWA to administer and implement the provisions of this chapter in accordance with Section 1.6.

The permittee(s) and responsible party has the responsibility to review, understand, and comply with the GESC or ESC plan or low risk guidance, as applicable. Several GESC program requirements pertaining to general construction practices are highlighted in the following sections.

6.1 LIMITS OF CONSTRUCTION

No construction activity, including storage of equipment, or stockpiling shall be allowed outside of the approved limits of construction. Any changes to the limits of construction must be approved by the County prior to field changes. At the County's discretion, additional control measures may be required in any additional areas of construction activity. The permittee(s) and responsible party shall be held responsible for obtaining permission and remediation for work offsite.

6.2 STREET CLEANING

Throughout the life of a project, streets used for egress shall be kept clean and free of sediment that can be tracked. In the event of tracking of material including sediment on streets, the material shall be cleaned immediately using a vacuum-type street sweeper, a brush-type street sweeper with dust control, or manually using shovels and brooms.

Any damage to the street from mechanical methods of street cleaning shall be repaired at the permittee(s) expense and may require additional coordination with the County.

Streets can only be cleaned with water if all wash water is captured within the limits of construction and prevented from entering the storm sewer system or environmentally sensitive areas. Any water used in washing activities that discharges from the site or enters the storm sewer system is a violation of the GESC program.

6.3 DUST CONTROL

The permittee(s) shall be responsible for dust control on the site. Disturbed areas not yet ready to be seeded, landscaped, paved, or otherwise stabilized, shall be watered, sprayed with a tackifier, mulched (without seed) or ripped as necessary to preclude visible dust emissions. The application of water used for dust control must be conducted in a manner to prevent discharges offsite.

Dust that leaves the site in any amount that can be considered a safety issue is not acceptable.

6.4 CONSTRUCTION SITE WASTE CONTROL

Many potential pollutants other than sediment are associated with construction site activities, as described in Section 6.4.

Responsible handling and adequate disposal facilities shall be utilized for solid waste, including excess asphalt, concrete, wood, rebar and other construction waste produced during construction.

Washing of equipment and machinery shall only be allowed on site if wash water is captured within the limits of construction and prevented from reaching the storm sewer system. Any water used in washing activities that discharges from the site or enters the storm sewer system is a violation of the GESC program.

Appropriately store, cover, and/or isolate onsite potential construction-associated waste pollutants to prevent runoff of pollutants and contamination of groundwater. The permittee(s) or responsible party are responsible for both the management and cleanup of potential construction waste. Outdoor storage of bulk liquids in individual containers of 55 gallons or greater containing petroleum or other liquid chemicals is required to have secondary containment or equivalent protective measures in place. Outdoor storage of any of the above items shall not be stored within the floodplain, unless otherwise approved by the County.

6.5 ADMINISTRATIVE CONTROLS

Administrative stormwater control measures are procedures, policies, and practices put in place to minimize or prevent the risk of pollution to stormwater discharges. Unlike structural control measures, which involve physical changes to equipment or the environment, administrative controls focus on reducing potential pollution through processes and guidelines. Administrative controls include:

- Work practices such as sweeping streets and frequently picking up trash from the site.
- Training and education such as training employees on proper waste disposal, material storage, and spill prevention and response.
- Phasing such as limiting exposure to disturbed area.
- Limiting or restricting access to designated areas such as restricting access to a site during wet conditions.
- Preserving existing vegetation onsite such as through the use of vegetation buffers near the site perimeter.

- Administrative controls and other non-structural control measures must be discussed as part of the narrative sheet in the GESC plan.

6.6 POTENTIAL POLLUTANTS AT A CONSTRUCTION SITE

Pollutant sources onsite must be identified and controlled using structural and/or non-structural controls using good engineering, hydrologic and pollution control practices. Detailed descriptions of control measures for pollution control are given in [Section 8](#). Though not an exhaustive list, the following are examples of common pollutant sources found on construction sites.

- **Sediment:** soils or other surficial materials transported or deposited by the action of wind, water, ice, or gravity, and often as a product of erosion.
- **Pesticides:** include but are not limited to, insecticides, fungicides, rodenticides, and herbicides used on construction sites to reduce maintenance and fire hazards associated with weeds and woody plants. Common insecticides employed include synthetic, relatively water-insoluble chlorinated hydrocarbons, organophosphates, carbamates, and pyrethrins.
- **Petroleum Products:** include fuels and lubricants for vehicles, for power tools, and for general equipment maintenance. Specific petroleum pollutants include but are not limited to gasoline, diesel oil, kerosene, lubricating oils, and grease. Asphalt paving also can be particularly harmful since it releases various oils for a considerable time after application. It should be noted that stormwater discharges from paved surfaces that will be initially sealed or re-sealed with high polycyclic aromatic hydrocarbons (PAHs) sealants are not eligible for coverage under the State Stormwater Construction General permit.
- **Nutrients:** include but are not limited to fertilizers, which contain nitrogen and phosphorus, and can adversely affect surface waters, causing eutrophication.
- **Solid wastes:** include but are not limited to wood and paper from packaging and building materials, scrap metals, sanitary wastes, rubber, plastic and glass, masonry and asphalt products, common trash, including food containers, cigarette packages, leftover food, and aluminum foil.
- **Construction chemicals:** include but are not limited to chemical pollutants, such as paints, acids for cleaning masonry surfaces, cleaning solvents, asphalt products, soil additives used for stabilization, sanitary wastes, and concrete curing compounds.

6.7 EQUIPMENT MAINTENANCE

When equipment maintenance is required to occur onsite, maintenance must be conducted in a designated location within the limits of construction. Maintenance should not be conducted within 50 feet of storm sewer inlets and/or environmentally sensitive areas.

6.8 SPILL AND LEAK CONTROL

Spills and leaks onsite must be minimized. Upon identification, spills must be cleaned using dry methods whenever possible. If water or other liquid methods are used, the wash water must be collected and disposed of properly. For spills that are an emergency, call 911. It is the responsibility

of the permittee(s) or responsible party to report any spills in accordance with federal, state, and local regulations. This includes any discharge of pollutants to state waters which shall be reported to the CDPHE-WQCD at 1-877-518-5608. All spills that impact the MS4 and/or state waters must be reported to the County at 720-874-6500. Failure to report spills to the County or failure to fully remediate any spills may result in enforcement.

Effective spill control is required to be implemented on construction sites. Onsite personnel must be trained on both spill prevention and spill response measures.

6.9 TEMPORARY AND FINAL STABILIZATION METHODS

All areas disturbed by construction, and soil stockpiles, shall be stabilized as soon as possible to reduce the duration of soil exposure to runoff events and the potential for erosion. All disturbed areas which are either final graded or will remain inactive for a period of more than 30 days, shall be required to be stabilized within 14 days of the completion of the grading activities. Active construction stockpiles shall not be placed within a floodplain unless approved by the County.

Acceptable stabilization control measures are defined in Table 6.1.

Table 6.1 SUMMARY OF ACCEPTABLE STABILIZATION CONTROL MEASURES ²

Temporary Stabilization Control Measures	Final Stabilization Control Measures
Surface roughening	Permanent hardscape (including, but not limited to concrete and/or pavement)
Seeding and mulching (temporary seed mix may only be used in area is inactive for 6 months or less, unless otherwise approved by the County)	Seeding and mulching
Erosion control blanket (without seed)	Erosion control blanket (with seed)
Hydromulch	Hydromulch (with seed)
Tarps (for stockpile areas)	Sod or landscaping (according to the approved landscape plans)

For temporary stabilization (i.e., areas that will be reworked), the GESC program requires one or more of the above. All stabilization control measures must be maintained. Temporary stabilization measures are generally only appropriate for areas that are inactive for 6 months or less.

Final stabilization is reached when construction activities at the site have been completed, permanent stabilization methods are complete, and temporary control measures are removed. Areas being stabilized with a vegetative cover must have evenly distributed perennial vegetation. The vegetation coverage must be, at a minimum, equal to 70 percent of what would have been provided by native vegetation in a local, undisturbed area or adequate reference site. Note that it is the permittee(s)'s responsibility to control noxious weeds in accordance with local and state law,

² Refer to Section 8 as applicable for discussion on stabilization control measures.

including List A Noxious Weeds which are required by the Colorado Department of Agriculture to be eradicated.

7 SITE GRADING DESIGN GUIDANCE AND CRITERIA

Within the SEMSWA service area, the County has delegated authority to SEMSWA to administer and implement the provisions of this chapter in accordance with Section 1.6.

This section provides design guidance and criteria for developing a proposed grading plan for a site. Although the existing topography and planned uses of development sites and individual lots are unique, several principles apply when designing permanent land surface grading.

7.1 TOPSOIL MANAGEMENT

Favorable topsoil is a critical component in establishing the required vegetative coverage for final stabilization and topsoil should be considered in the site assessment, design, and construction process. The depth of organic topsoil may vary on a site from several inches to eight inches or more.

The Mile High Flood District's *Topsoil Management Guidance* describes procedures for assessing topsoil characteristics on a site and designating the areas to place the most suitable topsoil during site improvements. The MHFD guidance is the basis of the topsoil management requirements specified in the GESC plan.

The following steps shall be undertaken during the GESC plan submittal process.

Topsoil sampling. Delineate distinct types of soil anticipated on a site considering NRCS soil types and visual clues such as prior site disturbance and quality of vegetation (dense, healthy vegetation generally absent of weeds is often an indicator of suitable soils, whereas soils in weedy areas should be avoided for use as proposed topsoil). Select at least three locations within each distinct soil type for sampling. At each sample location, use a soil auger or shovel to excavate and observe soils in 6-inch depth increments until a depth 6-inches inches into the subsoil is reached. If sampled topsoil appears uniform at several depths and in several sampling locations within a distinct soil type area, the uniform soils can be combined for lab testing; non-similar soils shall be lab tested individually and at least one lab test shall be performed for each distinct soil type area. In any case, a minimum of three samples shall be lab tested for any site.

Laboratory testing. Sampled topsoil shall be analyzed for agronomic parameters including texture, salts, organic matter, pH, and nutrients by an agronomic soils testing laboratory. A topsoil quality analysis shall be included as part of the GESC Narrative. Sampling and testing results will be the basis for characterizing the depth and quality of topsoil on a site and determining if the topsoil is adequate, requires amendment(s), or if importing topsoil is required.

Testing results are used to formulate specifications for the following, which shall be discussed in the GESC narrative:

- Selection or creation of seed mixes (if different from the County standard seed mix),
- Determination if adequate favorable topsoil exists onsite. Where favorable topsoil exists onsite, stripping, stockpiling, and re-spreading of a minimum of 6-inches of topsoil in areas to be vegetated shall be a mandatory practice.
- Assessment of the areas and depths of the most favorable topsoil on a site to specify to be placed in the most critical areas of a site for revegetation.
- If adequate quantities of favorable topsoil are not available onsite, soil amendments and/or the import of adequate topsoil will be required, as discussed below. A standard soil amendment recommendation includes fertilizer type, application rate per acre or 1,000 square feet, and application schedule.

The quality of topsoil can be analyzed based on test results using Table 7.1 (Piza, et al., 2020):

Table 7.1 TOPSOIL QUALITY

Parameter Classification	Soil Parameter	Test Name	Unsuitable Topsoil	Marginal Topsoil	Suitable Topsoil	Ideal Topsoil
Texture	Texture: % sand % Silt % Clay	Based on the USDA soil classification system, sand, silt and clay percent based on the hydrometer method after gravel sizes >2mm are removed	sand, clay (>45%)	sandy clay, loamy sand, silty clay, silt loam, silt clay (40-45%), and silty clay loam	sandy clay loam, and clay loam	sandy loam, loam
Texture	Gravel: >2 mm or #10 sieve	Sieve sizes based on the USDA soil classification system	>70 mm	40 – 70 mm	10 – 40 mm	<10 mm
Salts/Sodium	Salinity/Salts (EC) dS/m or mmhos/cm	Saturated Paste	>4 dS/m	>3 – 4 dS/m	2 – 3 dS/m	<2 dS/m
Salts/Sodium	Sodium Adsorption Ratio (SAR)	USDA 60 6(20b)	>13 SAR	>8 – 13 SAR	8 – 4 SAR	<4 SAR
Organic Matter Content	Organic Matter (%)	ASTM D2974	N/A	<1%	1% - 2%	>2%
Soil pH	pH	ASA/ASHTO	pH <5.0 or > 9.0	pH 5.0 - 8.5 or 8.5 - 9.0	pH 5.5 - 6.0 and 8.0 - 8.5	pH 6.0 - <8.0
Nutrients	Nitrate Nitrogen (ppm)	ASA2 33-3	N/A	<10 or >30	10 - <20 ppm	20 – 30 ppm
Nutrients	Phosphorus (ppm)	Ammonium bicarbonate - DTPA test	N/A	<8 ppm	8 – 15 ppm	>15 ppm

1. **Unsuitable topsoil.** For areas of onsite topsoil with any parameter that is unsuitable based on test results, that material is not adequate to use as topsoil. Topsoil from other areas of the site that have no unsuitable parameters or import of adequate topsoil should be quantified and proposed in the GESC narrative. Any topsoil import source shall be subject to the same sampling and testing requirements as onsite sources, with a minimum of three representative samples lab tested.

2. **Amendments.** For organic matter or nutrients found to be marginal based on test results, amendments should be proposed to change the quality from marginal to suitable or ideal. Compost used to increase organic matter shall be Class I according to the US Composting Council's STA and TMECC testing standards. The minimum application rate of Class I compost for topsoil in the marginal category for organic matter shall be 1,000 pounds per 1,000 SF. Commercial fertilizers shall be phosphorus free or of a slow release formulation such as Biosol. The minimum application rate of fertilizer for topsoil in the marginal category for low nitrogen shall be equivalent to 1.0 pound per 1,000 SF and the maximum application rate shall be equivalent to 2.0 pound of nitrogen per 1,000 SF.

Sites that will be stabilized independent of seed (hardscape, mulch, etc.) or have less than 1,000 square feet of proposed seed areas may be exempt from the topsoil quality analysis requirements, as determined by the County. Please refer to the County Land Development Code (LDC). In the case of conflicts between the LDC and GESC requirements for topsoil, the more stringent shall apply.

7.2 SLOPES

The measures in this section shall be taken to minimize erosion of slopes. Slopes must be 4:1 or flatter, unless infeasible. Slopes steeper than 4:1 require stabilization with erosion control blanket. Slopes steeper than 3:1 will require additional permanent measures to withstand erosion, and requires a variance from the County unless the grading is associated with channel side slopes.

7.3 STOCKPILES ASSOCIATED WITH GESC PERMITS

During design, earthwork balance and timing of construction will determine the necessity of stockpiling. If stockpiling of soils is anticipated, it must be noted on the GESC plan and must be within the approved limits of construction.

Construction stockpiles are a temporary condition and may include topsoil stockpiles, stockpiles associated with grading activity, and other similar stockpiling during construction. If soil is to be stockpiled for more than 30-days and not actively worked, it shall be seeded and mulched within 14 days of stockpiling. All construction stockpiles shall be located to maximize distance from the floodplain and other environmentally sensitive areas.

Stockpiles that are intended to remain in place after GESC permit close-out are not considered construction stockpiles and must be approved by the County. They shall be located in accordance with the approved GESC plan. If approved by the County, they must meet the following requirements:

- Side slopes of stockpiles must be flatter than 3:1. Appropriate control measures must be used.
- Shall not be located within the floodplain and must be located away from environmentally sensitive areas.
- Shall not be located on impervious areas.
- Maximum height of 10-feet unless otherwise approved by the County.
- Movement of the stockpile after final close-out of the GESC permit may require a new GESC or ESC plan and permit process.

- Stockpile size and location may require coordination with the County. Stockpile shall be blended into the final site grades, unless infeasible.

8 DESIGN, INSTALLATION, AND MAINTENANCE OF CONTROL MEASURES

Within the SEMSWA service area, the County has delegated authority to SEMSWA to administer and implement the provisions of this chapter in accordance with Section 1.6.

This section identifies several control measures approved for use to control pollutants from construction sites. This section of the GESC Manual provides the design parameters to be specified for each control measure on the GESC or ESC plan and the accompanying standard notes and details, criteria for sizing control measures, and required maintenance for each control measure.

The GESC or ESC plan submitted to the County for approval and subsequently provided to the permittee(s) shall include a set of the GESC or ESC Plan—Standard Notes and Details. If there is a conflict between the design, installation, and/or maintenance of a control measure in the GESC Manual and the GESC or ESC Plan—Standard Notes and Details, the County will determine the appropriate reference to use.

The GESC program recognizes that there will be new advances in the development of control measures that may prove effective, or even out-perform controls currently approved. The County may allow the installation of alternative control measures other than the GESC or ESC Plan—Standard Notes and Details. If alternative control measures will be used, a cut sheet must be submitted to and approved by the County.

The County reserves the right to reject any control measure proposed or conditionally implemented. If the control measure does not perform adequately, it would be considered a failed control measure by the inspector. In the case of a failed alternate control measure, one or more of the GESC program's standard control measures shall replace the failed control measure, at the permittee(s)'s expense.

The County standard control measures are listed below in alphabetical order.

8.1 CUT BACK CURB (CBC)

A cut back curb (CBC) control measure is a type of grade differential that acts as a temporary sediment trap created by excavation behind the curb, sidewalk, or roadway. This control measure's purpose is to intercept sediment-laden runoff from the site during construction and retain sediment. The hardscape (sidewalk, curb, or roadway) acts as a barrier to retain the stormwater long enough for the sediment to drop out before it leaves the site.

Sediment accumulation volume is sized for 1,800 cubic feet (CF) per acre of tributary area. 5' width and 6" depth is acceptable for tributary area widths (TAW) up to 60'. For tributary area widths (TAW) greater than 60', dimensions must be specified on GESC plan using the equation below. Do not use in areas with 3:1 slope or greater, or areas with concentrated flow. Cut back areas with a longitudinal slope greater than 2% should consider installing reinforced rock berms, sediment control logs, or

check dams to prevent concentrated flow along the length of the cut back area. CBC shall only be allowed along public roadways with adequate justification by the project geotechnical engineer.

$$\text{Width} = \text{Required Volume (CF)} / (\text{Length (L)} * \text{Depth(D)})$$

Design parameters to be specified on the GESC or ESC plan include the following items:

- Location of the CBC.
- Length (L) of the CBC.
- Width (W) of the CBC.
- Depth (D) of the CBC.

8.2 CHECK DAM (CD)

The purpose of the check dam (CD) is to trap sediment in the backwater zone upstream of the check and, when used in series, to reduce flow velocities. CDs are used only for construction activities within a concentrated flow area. CDs are not to be used to capture sediment transport within an active flowing stream. Appropriate control measures shall be used upland to keep sediment from entering the concentrated flow areas. CDPHE-WQCD does not recognize the use of any control measure within state waters. It is the permittee(s)'s responsibility to determine if any additional permitting is necessary for the placement of CDs within a drainageway.

In general, CDs will be used infrequently at typical construction sites since control measures shall be configured to control erosion and trap sediment outside of the limits of drainageways. Within jurisdictional waters, CDs may only be used with the appropriate Corps permit.

Dimensions are to be specified to ensure that the CD conforms to the drainageway cross section and shape and provides adequate overtopping capacity. Dimensions here are for 130 acres or less. CDs with alternate dimensions meeting site specific conditions may be proposed and approved by the County as part of the GESC or ESC plan review process.

The type of check is based on the drainage area upstream of the CD. The engineer shall specify control measure(s) to be used for drainage areas greater than or equal to 130 acres. A non-reinforced CD may be used for drainage areas less than 130 acres, or as approved by the County. A reinforced rock berm (RRB) may be used as a check dam for drainage areas less than 20 acres (see [Section 8.11](#)).

Dimensions are to be specified to ensure that the check conforms to the existing drainageway cross section shape and provides adequate overtopping capacity.

- Design parameters to be specified on the plan include the following items: Length (L) dimension.
- Width (W) dimension.
- Crest length (CL) dimension.
- Depth (D) dimension.

- Minimum size riprap shall be VL.

8.3 CONCRETE WASHOUT AREA (CWA) and GROUT WASHOUT AREA (GWA)

A concrete washout area (CWA) or grout washout area (GWA) is a contained area to isolate concrete truck and grout washout operations. A CWA shall be provided when concrete work is performed. A GWA shall be provided when grout work is performed.

If there is a potential for high groundwater, the CWA or GWA must have an impervious liner. For portable concrete washouts, sizing of the portable container should be per the manufacturer recommendations. Include a note on the plan that all proposed GWA operations will be determined in the field. The CWA or GWA shall be located a minimum of 50 feet from storm drain inlets, open conveyance channels, drainage facilities, waterways, and environmentally sensitive areas, unless infeasible, and must be located within the limits of construction.

8.4 CONSTRUCTION FENCE (CF)/CONSTRUCTION MARKERS (CM)

Construction fence (CF) consists of orange or flagged plastic fencing or other County-approved material attached to support posts and is used to delineate limits of construction and to control access to the construction site. When construction within a drainageway is unavoidable, the engineer shall delineate construction limits that restrict activities to the smallest area possible. CF or construction markers (CM) shall be indicated on the GESC or ESC plan within the drainageway corridor to indicate the allowable limits of disturbance. In the same manner, CF or CM shall be shown on the GESC or ESC plan throughout the site to identify all limits of construction, as shown on the approved GESC or ESC plan, except in the case of master developed subdivisions with single-family lot home construction.

CF or CM shall be shown throughout the site to identify the limits of construction. CF or an approved alternative method of delineating the project limit, such as silt fence, shall be required along all drainageways, including environmentally sensitive areas and any other areas that should be protected from disturbance.

Design parameters to be specified on the GESC or ESC plan include the following items:

- Location of construction fence or line of markers.
- Length (L) in linear feet of construction fence or line of markers.

8.5 STORMWATER DEWATERING (DW)

Stormwater dewatering controls typically consist of a gravel filter provided on the suction end of a pump to reduce the pumping of sediment, and a riprap pad at the discharge end of the pump for erosion protection. DW shall require an appropriately sized sediment basin or filter bag before the water is discharged onto the ground for infiltration or to a temporary settling basin. The County may require a Water Control Plan if site conditions warrant. This control measure applies to stormwater dewatering only. For dewatering that requires a CDPHE-WQCD Dewatering General permit, refer to

applicable dewatering permit requirements. Design parameters to be specified on the GESC or ESC plan include the following items:

- The location of all proposed DW operations.
- The recommended size of the dewatering pump. The size shall be determined to provide sufficient capacity for the proposed pumping rates. If dewatering operations are unknown at the time of design, include a note on the plan that all proposed stormwater dewatering operations and appropriate sizing will be determined in the field.

8.6 DIVERSION DITCH (DD)

A diversion ditch (DD) is a small earthen channel used to divert and convey runoff, generally to a sediment basin, sediment trap, check dam, or reinforced rock berm. Depending on slope, the DD may need to be lined with erosion control blanket, plastic, PVC, or riprap.

A temporary DD may be necessary at upslope and downslope perimeters, at the top of steep slopes, and downstream of slope drains. DD shall be sized and stabilized according to the criteria below.

- Design engineer to specify longitudinal slope, minimum width, depth, and if DD is lined or unlined based on-site conditions to include flow, longitudinal slope, soil type, etc.
- Unlined diversion ditches must have a slope equal to or less than 1%.
- General design guidelines based on longitudinal slopes exceeding 1% are as follows in the Table 8.1.

Table 8.1 DIVERSION DITCH LINING REQUIREMENTS BASED ON LONGITUDINAL SLOPE

Slope	Lining
>1% - 3%	Erosion control blanket (ECB) lined
>3% - 33%	Plastic or rip rap lined

- Dimensions shall be specified to ensure that the ditch adequately conveys runoff from a 2-year return period event for site conditions expected during the operation of the control measure. Ditches or drainageways conveying a 2-year flow rate exceeding 10 cfs shall require specific calculations and a design analysis by the engineer.

Design parameters to be specified on the GESC or ESC plan include the following items:

- Lining of DD (earth, Erosion Control Blanket, riprap, or plastic).
- Length of each type of ditch.
- Depth (D) and width (W) dimensions and slope.
- Location.
- In addition, if the ditch lining is erosion control blanket or riprap, the type of erosion control blanket and size of riprap (D50) needs to be specified.
- Runoff Rate.

8.7 EROSION CONTROL BLANKET (ECB)

Erosion control blanket (ECB) is a fibrous blanket of straw, jute, excelsior, or coconut material trenched in and staked down over prepared soil to reduce both wind and water erosion. ECB shall be required for any disturbed channel banks and all slopes steeper than 4:1. An ECB may be used for lining of a diversion ditch. The engineer shall indicate approximate limits of ECB, or equivalent, on the GESC or ESC plan.

All ECB shall have double sided netting. All ECB and netting should be made of 100% natural and biodegradable material and shall have a minimum product life of 2-years for channel bank applications and 12-month product life for slope applications.

ECB shall be specified based on the judgment of the engineer, but at a minimum, blanket in drainageways shall be sized for the shear stress from a 2-year, 24-hour storm event for site conditions expected during the operation of the matting. Table 8.2 provides the maximum shear stress and velocity, based on unvegetated channel conditions, for allowable types of ECB.

A double-net straw or excelsior blanket shall be used for all slopes steeper than 4:1, outside of drainageways. Concave slope areas that may concentrate sheet flows as well as all other drainage channels (up to the top of the banks) shall require a double-net 70% straw / 30% coconut, double-net 100% coconut, or double-net 100% excelsior blanket based on the shear stress and velocity of the new or disturbed channel. The shear stresses and velocities shown in Table 8.3 shall be considered the maximum allowable values. Channels where velocities and stresses exceed those shown in Table 8.3 shall require specific calculations and a design analysis by the engineer. A biodegradable double-net 100% coconut fiber ECB shall be used for seeded bioretention areas, grass buffers, and grass swales.

Shear stress and velocity in ditches and drainageways may be calculated based on the following formulas: Shear stress (lbs/sf) = $62.4 * D * S$, where:

D (ft) = maximum flow depth for the design (2-year, 24-hour storm event); S (ft/ft) = drainageway slope;

Velocity (ft/sec) = Q/A , where: Q (cfs) = flow rate for the (2-year, 24-hour storm event); A (sf)= cross-sectional area.

Table 8.2 EROSION CONTROL BLANKET TYPE

Type	Coconut Content (%)	Straw Content (%)	Minimum Weight (lbs/sy)	Manning's N Value (varies with depth as shown)	Allowable Max Sheer Stress (lbs/sf)	Allowable Max Velocity (fps)
Straw	0	100	0.5	0.081 for $D \geq 2.0'$ 0.050 for $D \leq 0.5'$	Not allowed in drainageways or Diversion Ditches	Not allowed in drainageways or Diversion Ditches
Straw-Coconut	30 (min)	70 (max)	0.5	0.081 for $D \geq 2.0'$ 0.050 for $D \leq 0.5'$	1.75	5.0
Coconut	100	0	0.5	0.081 for $D \geq 2.0'$ 0.050 for $D \leq 0.5'$	2.25	5.0
Excelsior	NA	NA	0.7	0.028 for $D \geq 2.0'$ 0.066 for $D \leq 0.05'$	2.00	5.0

For depths between 0.5 and 2.0-feet, the solution will be iterative, continuing until the depth corresponding to the Manning's N value is within 0.25-feet of the calculated depth. The maximum drainageway shear stress and velocity calculated using the above equations shall be less than the values indicated in Table 8.3 for the type of blanket specified. This criterion is for temporary ditches and permanent channels designed to be grass lined. For permanent channels, the types of ECB shown shall be considered to comprise temporary erosion control only until vegetation can be established. ECB, as discussed in this section, is to be provided for temporary stabilization of permanent drainageways or roadside ditches that have been designed to be stable with grass or vegetative lining. The ECB is to provide erosion protection until the vegetation is established.

Table 8.3 EROSION CONTROL BLANKET DESIGN CRITERIA FOR VELOCITY AND SHEER STRESS

Straw, Straw-Coconut, Coconut, and Excelsior ECB	Straw-Coconut, Coconut, and Excelsior ECB	Coconut and Excelsior ECB	Coconut ECB	Outside of the allowable range for ECB
Velocity 1-5 fps	Velocity 1-5 fps	Velocity 1-5 fps	Velocity 1-5 fps	Velocity >5 fps
Sheer stress 0.25-1.25 lbs/sf	Sheer stress 1.50-1.75 lbs/sf	Sheer stress 2.00 lbs/sf	Sheer stress 2.25 lbs/sf	Sheer stress >2.25 lbs/sf

Parameters to be specified on the GESC or ESC plan include the following items:

- Type of blanket (straw, straw-coconut, coconut, or excelsior); type of blanket shall be based on the shear stress associated with the design flow, as discussed above.
- Dimensions shall be specified to ensure that the blanket provides protection.
- Area (A)
- Location.
- Staking spacing dimensions on center shall be based on expected shear velocities.

8.8 GROUT MIXING STATIONS (GMS)

A grout mixing station (GMS) area is a contained area to isolate grout and mortar mixing operations. A GMS control measure shall be provided when masonry work of any size or dimension is to be performed.

The GMS shall be located a minimum of 50 feet from storm drain inlets, open conveyance channels, drainage facilities, waterways, and environmentally sensitive areas, unless infeasible, and must be located within the limits of construction.

Design parameters to be specified on the plan include the following items:

- A note that the location of all proposed GMS operations will be determined in the field.

8.9 INLET PROTECTION (IP)

Inlet protection (IP) consists of a small, reinforced rock berm and cinder block frame placed in front of (but not completely blocking) a curb inlet or around an area inlet to reduce sediment in runoff entering the storm sewer system.

Storm sewer inlets on a site shall be provided with IP control measure. The GESC or ESC plan shall specify whether the control measure is an area, sump, or continuous grade IP to be used in a particular location. The continuous grade IP is intended to trap sediment upstream of an inlet on a continuous grade street without causing any bypass of flow around the inlet. Sump and area IP is also designed to maintain inlet capacity after runoff flows over the wire-enclosed rock.

Determining the length of the reinforced rock berm to fit the inlet is the responsibility of the engineer, as is providing temporary IP in accordance with the GESC or ESC Plan—Standard Notes and Details.

Design parameters to be specified on the plan include the following items:

- Location of IP.
- Type of IP (either sump or continuous grade for curb-opening inlets, or area IP).
- Length of IP.

8.10 REINFORCED ROCK BERM (RRB) or REINFORCED ROCK BERM FOR CULVERT PROTECTION (RRC)

A reinforced rock berm (RRB) and a reinforced rock berm for culvert protection (RRC) consists of a linear mass of gravel enclosed in wire mesh to form a porous filter, able to withstand overtopping. The berm is heavy and stable and promotes sediment deposition on its upstream side. Culvert inlets on a site shall be provided with an RRB.

If used in a diversion ditch or small drainageway, dimensions are to be specified to ensure that the RRB or RRC fits the drainageway cross section shape and provides adequate overtopping capacity. Multiple RRBs or RRCs may be used as a check dam across swales and small drainageways for up to 20 acres of upstream drainage area. In any case, dimensions shall be specified to provide a storage volume equal to 1,800 cubic feet (CF) per upstream acre. RRB or RRC designed in series shall require a specific calculation and a design analysis by the engineer.

Design parameters to be specified on the plan include the following items:

- Length (L) dimensions.
- Depth (D) dimensions.
- Height (H) dimensions.
- Location.

8.11 SEDIMENT BASIN (SB)

A sediment basin (SB) is an impoundment that captures sediment-laden runoff and releases it slowly, providing prolonged settling times to capture coarse and fine-grained soil particles. Runoff from disturbed drainage areas exceeding 2 acres shall be treated in a SB. Runoff from disturbed areas up to 2 acres may be treated in a sediment trap (ST), or other comparable control measure.

The standard SB is appropriate for use for disturbed drainage areas up to 15 acres. For drainage areas greater than 15 acres, an alternate design approach will be required as approved by the County and justified with calculations included within the report. The SB discharge point must be appropriately sized and to a stabilized area that should not drain back into a disturbed area. Provide a stabilized emergency overflow spillway for rainstorms that exceed the capacity of the sediment basin volume and its outlet. Refer to sediment basin detail in the GESC Plan—Standard Notes and Details.

Sizing information for the SB design (based on providing a minimum initial storage volume equal to 1,800 cubic feet per upstream acre) shall be determined from Table 8.4. As shown on the GESC Plan—Standard Notes and Detail sheets, the standard SB features a pipe outlet drilled with a single column

of five orifice holes. The hole diameter shown in Table 8.4 will drain the upper 1.5 feet of the SB in about 40 hours.

The SB is an initial control measure that must be installed as soon as feasible after GESC permit issuance. The engineer must consider earthwork phasing to determine that the location of the SB is not infeasible.

Table 8.4 SIZING INFORMATION FOR STANDARD SEDIMENT BASIN

Disturbed Upstream Tributary Drainage Area	Basin Bottom Area (Asf)	Spillway Crest Length³(CL) (ft)	Hole Diameter (HD)⁴
1	512	2	One column of 1/2” holes
2	968	4	Two columns of 1/2” holes
3	145	6	Three columns of 1/2” holes
4	1922	8	One column of 1” holes
5	2450	10	One column of 1” holes
6	2888	12	Two columns of 1” holes
7	3362	14	Two columns of 1” holes
8	3872	16	Two columns of 1” holes
9	4418	18	Two columns of 1” holes
10	4802	20	Two columns of 1” holes
11	5408	22	Three columns of 1” holes
12	5832	24	Three columns of 1” holes
13	6272	26	Three columns of 1” holes
14	6962	28	Three columns of 1” holes
15	7442	30	Three columns of 1” holes

³ Table indicates values of crest length (CL) for a crest depth (CD) of 12”. Crest length (CL) must be adjusted accordingly for alternate crest depths (CD) to maintain the flow area of the spillway. Crest length (CL) dictates the minimum length of the shortest side of the spillway bottom area.

⁴ Each column consists of five orifice holes.

Outlet facilities for extended detention basins may be used as the SB outlet when designed in accordance with the County-approved drainage analysis, with proper outlet control measures in place. If the installation of a SB is infeasible, installation of multiple sediment traps or other volume-based control measures may be used, as approved by the County.

Design parameters shall be specified on the GESC or ESC plan and include the following items:

- Location.
- Outlet release design based on Table 8.4 below.
- Bottom area (sf).
- Crest length (CL).
- Orifice dimensions.
 - Diameter (HD).
 - Number of orifices (O).
 - Number of Columns (C).
 - Riser Pipe Diameter (D).

8.12 SEDIMENT CONTROL LOG (SCL)

A sediment control log (SCL) consists of a cylindrical bundle of excelsior, straw, or coconut material designed to form a semi-porous filter, able to withstand overtopping and undermining.

In most cases, SCL shall be located on the contour. SCL may be shown running up or down slight slopes.

Generally, the maximum allowable tributary drainage area per 50 lineal feet of SCL, installed along the contour, is approximately 5,000 sq ft depending on the slope. Longer and steeper slopes require additional measures. This recommendation only applies to SCL installed along the contour. When installed for other uses, such as perimeter control, it should be installed in a way that will not produce concentrated flows. For example, a "J-hook" installation may be appropriate to force runoff to pond and evaporate or infiltrate in multiple areas, rather than concentrate and cause erosive conditions parallel to the SCL. SCL shall not be used across drainageways.

Design parameters to be specified on the GESC or ESC plan shall include the following items:

- Location of the SCL.
- Length (L) of the SCL.

8.13 SEDIMENT TRAP (ST)

A sediment trap (ST) consists of a riprap berm with a small upstream basin that acts to trap coarse sediment particles. It may be used for upstream disturbed areas less than 2 acre. To treat runoff from disturbed areas 2 acres or greater, refer to [Section 8.11](#) Sediment Basin.

Sediment trap dimensions shall be specified to provide a storage volume equal to 1,800 cubic feet per upstream acre. Sediment traps designed in series shall require a specific calculation and a design analysis by the engineer. Overtopping should occur on stabilized surfaces, to include well-vegetated areas, riprap, or pavement.

Design parameters shall be specified on the GESC or ESC plan and include the following items:

- Location, length (L), width (W), and volume (V) dimensions.

8.14 SEEDING AND MULCHING (SM)

Seeding and mulching (SM) consists of drill seeding disturbed areas with the approved County seed mix and crimping in straw mulch to provide immediate protection against water and wind erosion and, as the grass cover becomes established, to provide long-term stabilization of exposed soils.

If the time of year does not allow for seeding operations to be effective, the permittee(s) may be granted an extension on the seeding requirement. In such cases, a revised seeding schedule must be approved by the County. Until seeding can occur, the area must be temporarily stabilized in accordance with [Section 6.9](#).

Temporary irrigation is highly encouraged to assist with growth of vegetation. Stockpiles and areas that are being temporarily seeded do not require topsoil prior to seeding and mulching.

Design parameters to be specified on the GESC or ESC plan include the following items:

- Area (A) in acres to be SM.
- Type of seed mix and location of each type of seed mix.

All projects include a seed mix recommendation provided by a qualified professional with sufficient knowledge of the project, including a landscape architect, engineer, or ecologist. If a qualified professional does not provide a seed mix, then the County's standard seed mix shall be specified.

8.15 SILT FENCE (SF)

Silt fence (SF) or reinforced silt fence (SFR) is a temporary sediment barrier constructed of woven fabric stretched across supporting posts. The bottom edge of the fabric is placed in an anchor trench that is backfilled with compacted soil.

Silt fence works most effectively when placed on relatively level ground to capture and filter approaching sheet flow. It is not suited for concentrated flow or for large upstream drainage areas. The following criteria shall apply to the use of SF:

- Silt fence shall not be used across swales or drainageways.
- Silt fence shall be located along the contour lines of a slope. Silt fence may be shown running up or down slight slopes.
- When SF is not installed along the contour, a "J-hook" installation may be appropriate to ensure that the control measure does not create concentrated flow parallel to the SF. J-hooks are small sections of SF or an equivalent control measure installed as a series of check structures perpendicularly abutting a continuous row of SF.

- The average upslope length of the area draining to an individual section of SF shall not exceed 100 disturbed feet and the total area draining to a section of SF shall not exceed 10,000 square feet of disturbed area.

Silt fence located at the toe of a slope should be placed a minimum of 5 feet offset from the toe to allow for maintenance activities.

Silt fence used to protect major drainageways or other sensitive stormwater areas, as determined by the County, from upland construction activities shall be wire-backed.

Design parameters to be specified on the GESC or ESC plan include the following items:

- Location.
- Length (L) in linear feet.
- Type of silt fence (SF or SFR).

8.16 SLOPE INTERCEPT DITCH (SID)

A slope intercept ditch (SID) is a small earth channel with accompanying earthen berm installed along the contour used to slow stormwater surface flows. A SID can also be used to prevent run-on of stormwater surface flows from undisturbed areas contiguous with the construction site.

Minimum SID depth shall be 10 inches. Compacted berm from SID spoils shall be a minimum 10 inches in height. A SID can be used in place of silt fence and sediment control log in certain applications, as approved by the County.

Design engineer to specify longitudinal slope, minimum width, and if a SID is lined or unlined based on site conditions to include flow, longitudinal slope and soil type, etc.

Design parameters to be specified on the GESC or ESC plan include the following items:

- Location.
- Length (L) in linear feet of each SID.

8.17 STABILIZED STAGING AREA (SSA)

A stabilized staging area (SSA) consists of stripping topsoil and spreading a layer of angular granular material in the area to be used for a trailer, equipment, parking, storage, unloading and loading.

A SSA shall be provided near the main access point and shall be connected to the Vehicle Tracking Control, unless infeasible.

Gravel or road base may be used for the SSA. The use of recycled asphalt or concrete as granular material is not allowed.

Design parameters to be specified on the GESC or ESC plan include the following:

- Location of SSA.
- Approximate area (A) in square yards of the SSA.

8.18 STREET SWEEPING (SS)

Street sweeping (SS) consists of cleaning sediment, mud, and other construction material which is tracked onto impervious surfaces at a construction site. Street sweeping shall be used for incidental tracking and is not to be used as a perimeter control measure or as the sole control measure.

Any damage from sweeping public streets and sidewalks may require repair to the street and shall be paid for by the permittee(s). Likewise, any damage to construction control measures from sweeping activities may require repair.

Material tracked onto impervious surfaces shall be cleaned using a vacuum-type street sweeper, a brush-type street sweeper with dust control, or manually using shovels and brooms. Ensure all appropriate permits for sweeping public streets and sidewalks are obtained. Streets shall not be washed with water at any time unless all water is contained and collected.

No design is required for SS.

8.19 SURFACE ROUGHENING (SR)

Surface roughening (SR) consists of creating a series of grooves or furrows along the contour of the slope in all disturbed, graded areas to trap stormwater and reduce the formation of rill and gully erosion. Surface roughening provides a layered control measure approach, or treatment train approach to limit runoff and sediment transport.

Surface roughening is an erosion control practice that involves tracking, scarifying, imprinting, or tilling a disturbed area to provide temporary stabilization. Surface roughening shall be used on disturbed areas throughout the site during the initial/interim stages, unless infeasible. Surface roughening creates variations in the soil surface that help to minimize wind and water erosion. Depending on the technique used, SR may also help establish conditions favorable to establishment of vegetation. Surface roughening can be used to provide temporary stabilization of disturbed areas, such as when revegetation cannot be immediately established due to seasonal planting limitations. Surface roughening is not a stand-alone control measure and should be used in conjunction with other control measures. Surface roughening is often implemented in conjunction with grading and is typically performed using heavy construction equipment to track the surface. Be aware that tracking with heavy equipment will also compact soils, which is not desirable in areas that will be revegetated. Scarifying, tilling, or ripping are better SR techniques in locations where revegetation is planned.

Design parameters to be specified on the GESC or ESC plan include the following:

- Approximate area (A) of disturbed soil that may require SR.

8.20 TEMPORARY SLOPE DRAIN (TSD)

A temporary slope drain (TSD) is a small culvert, plastic-lined rundown or riprap rundown to convey runoff down a slope or channel bank to reduce the occurrence of rill and gully erosion.

A TSD shall be used to convey runoff down a channel bank or slope. When a ditch constructed to convey runoff intersects a slope or channel bank, a TSD consisting of pipe, plastic liner, or riprap, shall be required to convey diverted water from the ditch down the slope or channel bank. The TSD

shall provide capacity equal to a 2-year, 24-hour storm event for site conditions expected during the operation of the slope drain.

Design parameters to be specified on the GESC or ESC plan include the following items:

- Type of TSD (pipe, riprap lined, or plastic lined).
- Location.
- Length (L) in linear feet.
- Pipe Diameter “D” dimension and riprap size “D50”, as applicable.

8.21 TEMPORARY STREAM CROSSING (TSC)

A temporary stream crossing (TSC) consists of culverts covered with rock to allow construction equipment to cross a drainageway. Excavation of the existing channel and disturbance is to be kept to a minimum. The number of vehicular and equipment crossings shall also be minimized.

Crossing drainageways with construction equipment requires a TSC. Appropriate control measures shall still be used to keep sediment from entering the drainageway. The State does not recognize the use of any control measure within state waters. It is the permittee(s)’s responsibility to determine if any additional permitting is necessary for the placement of any control measures within a drainageway. In addition, the County may require a Water Control Plan.

The type of TSC is based on the presence of baseflow and the shape of the channel. If there is any baseflow present, or the channel is relatively deep and narrow, a culvert crossing shall be used. The culvert should be sized to convey the entire design flow, see design flow considerations below. A culvert that is twice the required width should be installed, as feasible, for decreased maintenance frequency and increased factor of safety. Pipe class, minimum cover, etc. must ensure that the culverts will bear the loads associated with the type of vehicles that may use the crossing. The structural capacity of the crossing requires analysis by the engineer.

Design parameters to be specified on the GESC or ESC plan include the following items:

- Location of TSC.
- Length (L), height (H), crest length (CL), depth (D), culvert diameter (CD).
- For culvert crossings, the engineer shall specify:
 - Pipe class or gauge.
 - Minimum cover.

Culvert design flow considerations:

- Stream flow estimation.
 - Theoretical flow estimation methods can introduce additional uncertainty to the specified design flow. Stream gauge data or in-field measurements are preferred methods to estimate baseflow and other return events.

- Seasonality
 - Summer months have a higher chance of thunderstorms and rainfall events which could lead to higher-than-expected stream flow. Provide an additional factor of safety for projects constructed in the summer months.
 - If in-field measurements are taken at a different time of year than construction, adjust baseflow estimation to align with the expected baseflow during construction. Or re-measure stream flow just prior to the beginning of construction.
- Construction Duration
 - Short (< 1month) construction durations have a smaller probability of a significant rainfall event occurring than long (> 3months) construction durations. Provide an additional factor of safety for projects with longer construction durations. The culvert shall have capacity for the 2-year return event flows for construction durations longer than 1 year.
- Probability of exceeding culvert capacity. Consider the consequences of the following in the instance of exceedance or failure:
 - Public Safety.
 - Legal/Regulatory.
 - Environmental.
 - Cost.
 - Project Delays.
- Cost
 - Consider the cost of the temporary stream crossing versus the total project cost. If providing a culvert with adequate capacity is costly, use engineering judgement to provide alternate culvert configurations that consider the costs and benefits relative to the protection they provide.
- Wildlife and Water Quality
 - Consider the impact of any aquatic species in the stream as well as any special water quality conditions.

In any case, the engineer shall specify a culvert that thoughtfully considers the context of the site. Engineering judgement shall be used to specify a culvert that can convey the flows that are expected during construction while accounting for the implications if the culvert's capacity is exceeded. The minimum design flow for any project should be equal to the baseflow in the stream plus the capacity to convey the additional runoff from a storm event that is reasonably expected to occur during construction.

8.22 VEHICLE TRACKING CONTROL (VTC)

Vehicle tracking control (VTC) consists of a rock pad that is 12 inches thick at all vehicular exit points from disturbed areas internal to and leaving a site. VTC stone shall be angular in shape and resistant to weathering. Rounded stone or boulders will not be acceptable. The stones shall not be smaller than 3 inches in size. VTC is intended to strip sediment and debris from tires prior to vehicles and equipment leaving the construction site.

The number of access points at a construction site shall be minimized.

VTCs with alternate dimensions for site specific conditions may be proposed and approved by the County.

The use of recycled asphalt or concrete as granular material is not allowed.

Design parameters to be specified on the GESC or ESC plan include the following:

- Location of all VTCs.
- Length (L) of VTC.
- Width (W) of VTC.

8.23 VEHICLE TRACKING CONTROL WITH WHEEL WASH (WW)

Vehicle tracking control with wheel wash (WW) does not need to be specified as part of the design process. It shall be used if required by the County. Typically, if vehicle tracking onto public streets is a repetitive violation, a WW will be required.

In addition to a VTC as specified in [Section 8.23](#), a WW includes a gravel and riprap pad at the main exit point for the site with an adjacent wash water sediment trap.

The use of recycled asphalt or concrete as granular material is not allowed.

9 DEFINITIONS

Within the SEMSWA service area, the County has delegated authority to SEMSWA to administer and implement the provisions of this chapter in accordance with Section 1.6.

9.1 Applicant

An applicant refers to an individual or entity who is applying for a GESC or ESC permit. They are responsible for submitting the GESC or ESC plan. The applicant is responsible for reviewing, understanding, and complying with the GESC or ESC plan or low risk guidance. They are legally responsible for the permit's compliance and may be an individual or an authorized agent of an entity.

9.2 Authorized Agent

An authorized agent may be appointed by the applicant or responsible party to represent them in matters related to obtaining permits, complying with the GESC or ESC permit requirements, and addressing any issues or violations that may arise during the construction process. They are responsible for understanding and adhering to the applicable regulations and ensuring that the

necessary actions are taken to comply with the requirements. The authorized agent may be an employee, consultant, attorney, or any other individual or entity designated by the [applicant](#) to act on their behalf in matters related to the GESC or ESC permitting process.

9.3 Burden of Proof

The obligation resting on a party to provide sufficient evidence for their position.

9.4 Cherry Creek Watershed

The Cherry Creek Watershed consists of all lands that drain into the following: (a) the mainstem of Cherry Creek, from the source of East and West Cherry Creek to the inlet of Cherry Creek Reservoir (Segment 1), including alluvial groundwater; (b) Cherry Creek Reservoir (Segment 2), including alluvial groundwater; (c) all tributaries to Cherry Creek, including wetlands and alluvial groundwater, from the sources of East and West Cherry Creeks (parts of Segment 4); and all lakes and reservoirs in the Cherry Creek Reservoir watershed (Segment 5, in part) as described in the Classifications and Numeric Standards—South Platte River Watershed, Regulation #38 (5 CCR 1002-38). The Cherry Creek watershed is delineated in Figure 1 attached to CR 72 (5 CCR 1002-72). Classified State Water: A classified state water is a state water with a classification in the Classification and Numeric Standards Regulation for each of the seven river basins in Colorado. Classifications for each segment within the river basin can be found in the numeric and standards table for each basin regulation.

9.5 Collateral

Collateral refers to security provided to ensure compliance with the requirements of GESC Program. This security can take the form of an irrevocable letter of credit or a cash escrow.

9.6 Common Plan of Development or Sale

A contiguous area where multiple separate and distinct construction activities may be taking place at different times on different schedules, but remain related. “Contiguous” means construction activities located in close proximity to each other (within ¼ mile). Construction activities are considered to be “related” if they share the same development plan, builder or contractor, equipment, storage areas, etc.

9.7 Construction Activities

Refers to ground surface disturbing and associated activities (land disturbance), which include, but are not limited to, clearing, grading, excavation, demolition, installation of new or improved haul roads and access roads, staging areas, stockpiling of fill materials, and borrow areas. Construction does not include routine maintenance to maintain the original line and grade, hydraulic capacity, or original purpose of the facility. Activities to conduct repairs that are not part of routine maintenance or for replacement are construction activities and are not routine maintenance. Repaving activities where underlying and/or surrounding soil is exposed as part of the repaving operation are considered construction activities. Construction activity is from initial groundbreaking to final stabilization regardless of ownership of the construction activities.

9.8 Control Measure

Any best management practice or other method used to prevent or reduce the discharge of pollutants to state waters. Control measures include, but are not limited to best management practices. Control measures can include other methods such as the installation, operation, and maintenance of structure controls and treatment devices.

9.9 Control Regulation 72 (CR 72)

The Cherry Creek Reservoir Control Regulation (5 CCR 1002-72) (2024).

9.10 Dewatering General Permit

CDPS permit issued by the Water Quality Control Division for the discharge of construction dewatering source water to state waters. Construction dewatering source water means groundwater, surface water, and stormwater that have mixed with the groundwater and/or surface water (i.e., commingled stormwater runoff) that has come into contact with construction activities.

9.11 Engineer's Cost Estimate (ECE)

The estimated cost associated with implementing both initial/interim and final stabilization control measures. The ECE quantifies the financial guarantee necessary to ensure that the control measures are implemented and maintained until final stabilization is achieved.

9.12 Environmentally Sensitive Areas

Areas that have been identified for protection during the construction process. These areas include, but are not limited to, floodplains, waterways, wetlands, or other areas with significant ecological value, such as habitats for endangered species.

9.13 Erosion and Sediment Control (ESC) Permit

Erosion and sediment control permits apply to construction activities that disturb less than one acre of land and are not part of a larger common plan of development or sale that would disturb one acre or more. These permits are required to ensure that appropriate control measures are implemented to minimize pollution and sedimentation from construction activities, protecting water quality and preventing adverse impacts on drainage patterns, adjacent properties, floodplains, and waterways.

9.14 Final Stabilization

Final stabilization is reached when construction activities at the site have been completed, permanent stabilization methods are complete, and temporary control measures are removed. Areas being stabilized with a vegetative cover must have evenly distributed perennial vegetation. The vegetation coverage must be, at a minimum, equal to 70 percent of what would have been provided by native vegetation in a local, undisturbed area or adequate reference site. Note that it is the permittee's responsibility to control noxious weeds in accordance with local and state law, including List A Noxious Weeds which are required by the Colorado Department of Agriculture to be eradicated.

9.15 Good Engineering, Hydrologic and Pollution Control Practices

Methods, procedures, and practices that:

- Are based on basic scientific fact(s).
- Reflect best industry practices and standards.
- Are appropriate for the conditions and pollutant sources.
- Provide appropriate solutions to meet the associated permit requirements, including practice-based and numeric effluent limits.

9.16 Grading, Erosion, and Sediment Control (GESC) Inspector (Inspector)

A County staff who visits construction sites to check for compliance with the GESC permit.

9.17 Grading, Erosion, and Sediment Control (GESC) Manager

On-site representative who serves as the permittee(s) contact person with the inspector and who is responsible for ongoing compliance with the GESC permit. A GESC manager is an individual designated by the permittee(s) who is responsible for ensuring that a construction site complies with the GESC plan and permit requirements.

9.18 Grading, Erosion, and Sediment Control (GESC) Permit

A GESC permit is a regulatory authorization required by the County for construction activities that disturb one acre or more of land, or smaller projects that are part of a larger common plan of development disturbing one acre or more. Certain smaller projects may also require a GESC permit if they have the potential for significant environmental impacts.

9.19 Grading, Erosion, and Sediment Control (GESC) Program

The GESC program is a regulatory framework established by the County to ensure environmentally sound construction practices during land-disturbing activities. The program aims to prevent or minimize stormwater pollution from construction activities by enforcing the design, implementation, and maintenance of control measures. The GESC program includes the GESC permit, the ESC permit, and the low risk erosion and sediment control process.

9.20 Hold Harmless Letter for Early Start of Grading

A hold harmless letter for early start of grading is a document signed by the applicant that agrees to indemnify and hold the County harmless from any claims, damages, or liabilities arising from the applicant's construction activities. This letter is part of the conditions required to perform early grading on a site where development approvals are imminent but before having approved construction documents.

9.21 Illicit Discharge

Any discharges to an MS4 that is not composed entirely of stormwater except discharges specifically authorized by a CDPS or NPDES permit and discharges resulting from emergency firefighting activities, or otherwise in conformance with the County's MS4 permit.

9.22 Inadequate Control Measure

Any control measure that is not designed, implemented, or operating in accordance with the GESC Manual, and implemented and maintained to operate in accordance with the design.

9.23 Infeasible

Not technologically possible, or not economically practicable and achievable in light of best industry practices.

9.24 Land Disturbing Activity

Any activity that results in a change in the existing land surface (both vegetative and non-vegetative). Land disturbing activities include, but are not limited to clearing, grading, excavation, demolition, installation of new or improved haul roads and access roads, staging areas, stockpiling of fill materials, and borrow areas. Compaction that is associated with stabilization of structures and road construction shall also be considered a land disturbing activity. In the Cherry Creek Basin, a land disturbance means a human-made change in the natural cover or topography of the land, including grading, cutting and filling, building, paving, excavating and any other activities that may result in or contribute to soil erosion or sedimentation in state waters or the discharge of pollutants, except individual home construction.

9.25 Limits of Construction

Area shown in the GESC plan that delineates areas in which construction activities can take place including staging, storage, and stockpiling.

9.26 Low Risk Construction Activity

Refers to projects that are deemed to have a lower potential for causing significant environmental impact due to their limited scale or specific site conditions. Low risk construction activities are also less than one acre, and not part of a larger common plan of development or sale that disturbs one acre or more.

9.27 Major Modifications

Major modifications to a plan are those involving re-engineering or changes to site hydrology (e.g., increased area tributary to a control measure; site conditions beyond the limits of a control measure; eliminating a control measure; changes to grading, drainage, or design intent).

9.28 Minimize

Reduce or eliminate to the extent achievable using control measures that are technologically available and economically practicable and achievable in light of best industry practice.

9.29 Minor Modifications

Minor GESC modifications generally include control measure substitutions for other measures that are equivalent in performance and/or are more suitable to specific site conditions.

9.30 Municipal Separate Storm Sewer System (MS4)

State, city, town or other public entity-owned conveyance or system of conveyances (including roads with drainage systems, municipal streets, catch basins, curbs, gutters, ditches, human-made channels, or storm drains) designed to collect or convey stormwater.

9.31 Non-Structural Control Measure

Includes control measures that are not structural control measures, and include, but are not limited to, control measures that prevent or reduce pollutants being introduced to water or that prevent or reduce the generation of runoff or illicit discharges.

9.32 Operator

The party that has operational control over day-to-day activities at a project site which are necessary to ensure compliance with the permit. This party is authorized to direct individuals at a site to carry out activities required by the permit (e.g., the general contractor).

9.33 Owner

The party that has overall control of the activities and that has funded the implementation of the construction plans and specifications. This is the party that may have ownership of, a long-term lease of, or easements on the property on which the construction activity is occurring (e.g., the developer).

9.34 Permittee(s)

A permittee(s) refers to the owner and operator after the permit has been issued. The permittee(s) is responsible for complying with the applicable GESC program permit requirements.

9.35 Responsible Party

A responsible party is a person or entity legally accountable for compliance with the low risk guidance process.

9.36 Routine Maintenance

Any control measure that is still operating in accordance with its design and the requirements of the GESC Manual but requires preventative maintenance to prevent a breach of the control measure in subsequent storms.

9.37 State Waters (of Colorado)

Any and all surface waters and subsurface waters which are contained in or flow in or through this state, but does not include waters in sewage systems, waters in treatment works of disposal systems, waters in potable water distribution systems, and all water withdrawn for use until use and treatment have been completed. This definition can include water courses that are usually dry.

9.38 Stormwater

Stormwater runoff, snow melt runoff, and surface runoff and drainage.

9.39 Structural Control Measure

Includes control measures that are comprised of facilities and structures that remove pollutants from water or retain, reuse, or provide for infiltration or evaporation of water.

Appendices

Appendix A–GESC Program Permitting Matrix

Arapahoe County Grading, Erosion, and Sediment Control (GESC) Manual Permitting Matrix

	Description	Example Projects	Plan/ Permit ¹
Exempt Activities	Construction Activities ² with no earthwork or land disturbance; projects that are exempted by law, such as agriculture; construction activities with a R-Factor waiver. Activities that include routine maintenance to maintain original line and grade, hydraulic capacity, or original purpose of the facility ³ .	Mowing, cemetery graves, weed control, irrigation, routine maintenance of roads and parking lots with no land disturbance, agricultural activities.	NO/NO
Low Risk Process	Construction Activities ² disturbing less than 1 acre and not part of a larger common plan of development or sale that disturbs 1 acre or more, not expected to contribute sediment to the stormwater system with low potential of causing a water quality impact and/or a violation of a water quality standard. Does not include Construction Activities that have the potential to adversely impact drainage patterns or result in sedimentation of the stormwater system. These projects have the lowest risk to stormwater quality and can be self-regulating via fact sheets ⁴ .	Single family homes, utility boring, residential additions, building additions, park and green space projects, residential solar panel installation, building demolition, sidewalks, monument signage, pipe relining.	NO ⁴ /NO
Erosion and Sediment Control (ESC) Permit	Construction Activities ² disturbing less than 1 acre and not part of a larger common plan of development or sale that disturbs 1 acre or more and meets one or more of the following conditions: <ul style="list-style-type: none"> • requires a land use review process; • includes post-construction water quality; • includes public storm infrastructure, projects with impacts to floodplain; • linear transportation and utility projects that don't qualify for a Low Risk Process. 	Road widening projects, small commercial infill projects, improvements to public infrastructure, scrape and redevelop projects, park and green space projects, commercial solar panel installation.	YES*/YES *Sketch plan should meet requirements outlined in the GESC Manual
Grading, Erosion, and Sediment Control (GESC) Permit	All Construction Activities ² equal to or greater than 1 acre of disturbance, or less than 1 acre if part of a larger common plan of development or sale, unless otherwise excluded. Construction affecting drainage patterns, floodplain, or environmentally sensitive areas, even if less than 1 acre of disturbance and not part of a larger common plan of development or sale.	New building construction, residential subdivision development, mass grading projects, roadway expansion, stream stabilization.	YES/YES

¹ This is only for the GESC Permit; other permits may be necessary or required.

² Construction activity refers to ground surface disturbing and associated activities, which include, but are not limited to, clearing, grading, excavation, demolition, installation of new or improved haul roads and access roads, staging areas, stockpiling of fill materials, and borrow areas.

³ Activities to conduct repairs that are not part of regular maintenance and activities that are for replacement are considered construction activities and are not considered routine maintenance.

⁴ See Low Risk Fact Sheets in the County's GESC Manual. For Low Risk sites within the Cherry Creek Basin, the County Fact Sheet will suffice as an erosion and sediment control plan.

Appendix B—Utility Construction Activity in Unincorporated Arapahoe County Outside of the SEMSWA Service Area

Utility Construction Activity in Unincorporated Arapahoe County Outside of the SEMSWA Service Area

The installation and maintenance of utility lines in excess of 1,000 linear feet open cut and/or trench in unincorporated Arapahoe County outside of the Southeast Metro Stormwater Authority (SEMSWA) service area requires a GESC Permit. Installation and maintenance of utility lines less than 1,000 linear feet open cut and/or trench within County right-of-way do not require a GESC permit, but must comply with the GESC requirements associated with a Street Cut Right-of-Way Use/Pothole Permit as issued by the County.

All applicable construction activities, including utility projects, require a GESC permit within the County's municipal separate storm sewer system (MS4) permit area.

Utility Construction Requiring a GESC Permit

Utility line projects which require a GESC permit must adhere to the permitting process and submittal requirements set forth in the *GESC Manual* and the additional requirements listed in this Appendix.

1. All utility work within Arapahoe County right-of-way shall be required to obtain an Arapahoe County Street Cut Right-of-Way Use/Pothole Permit in accordance with the *Infrastructure Design and Construction Standards*, as amended.
2. Provide adequate erosion and sediment controls.
3. At the end of a work day, no trench shall be left open. The trench shall be either backfilled to grade, or a steel plate shall be placed over the open portion of the trench. The steel plate shall be positioned and anchored in accordance with all applicable safety criteria and such that stormwater will not enter the trench.
4. Where consistent with safety and space considerations, excavated material is to be placed on the uphill side of trenches.
5. At NO time shall excavated material be placed in the curb, gutter, sidewalk, or in the street within 6-feet of the flowline.
6. Limits of construction shall be large enough for a work area, temporary storage of excavated material and imported material, and equipment access to the project.
7. Downslope perimeter controls shall be installed to the downslope perimeters of construction disturbance (generally the downhill site perimeters), perimeters along drainageways, and downslope perimeters adjacent to other areas to be left undisturbed. Sediment controls shall be located as close to the source of erosion as possible, on the downslope side of any disturbed area.
8. Trench dewatering devices must comply with Colorado's dewatering general permit program (<https://cdphe.colorado.gov/dewatering-general-permit-program>) and the GESC Standard Notes and Details.
9. Inlet Protection shall be provided whenever soil erosion from the excavated area has the potential of entering a storm sewer system. All disturbed areas shall be drill seeded and crimp mulched within 7 days after utility work is completed. For larger

projects, seeding and mulching shall be done in phases rather than at the end of construction.

Utility Construction Covered Under a Street Cut Right-of-Way Use/Pothole Permit

Utility line projects which do not require a GESC permit must adhere to the GESC requirements associated with a Street Cut and Right-of-Way Use/Pothole Permit as issued by the County. The following summarizes the requirements for utility projects covered under a Street Cut and Right-of-Way Use/Pothole Permit (does not require a GESC Permit).

1. **Drawings.** GESC drawings will not be required unless the work to be performed is out of the ordinary or is located in a sensitive area. The contractor must use approved Arapahoe County construction control measures and maintain them throughout the construction process.
2. **Collateral.** The County will generally not require additional collateral for GESC requirements covered under a Street Cut and Right-of-Way Use/Pothole Permit, as long as the contractor actively maintains their control measures. The County will require additional collateral if the County determines that the contractor is not maintaining their control measures and the site may negatively affect water quality.
3. **Enforcement.** The Street Cut and Right-of-Way Use/Pothole Permit may be revoked and a stop work order may be issued if the County finds the permittee to be noncompliant with the GESC requirements under the Street Cut and Right-of-Way Use/Pothole Permit. When the contractor corrects the deficiencies, the County shall be notified and the Permittee will be required to attain new permits and pay a fee in accordance with the current County Fee Schedule and *Enforcement Response Plan* and additional collateral will be collected. The County may also require the contractor to obtain a GESC permit.
4. **General Construction Control Measures.** The Permittee must also adhere to the list of requirements provided below.

Pre-Construction Control Measures

1. Develop and implement erosion and sediment control plans and practices for the specific project that is being constructed.
2. Schedule excavation and grading work for dry weather.
3. Identify all storm drains, drainage swales, and state waters located near the construction site and make sure all subcontractors are aware of their locations to prevent pollutants from being discharged from the site.
4. Delineate clearing limits, easements, and setbacks, sensitive or critical areas, trees, drainage courses, and buffer zones to prevent excessive or unnecessary disturbances and exposure. Phase in the process of clearing and grubbing the site on an as-necessary basis rather than clearing and grubbing the entire work zone at one time. This will prevent a maintenance item until that the area is under active construction.
5. Implement a "Concrete Washout Area" control measure on the job site in accordance with the GESC Standard Notes and Details or return any unused concrete to the batch plant for disposal.
6. Designate one area for parking, equipment/vehicle refueling, and routine maintenance. The designated area should be well away from gutters, storm drains, and creeks.

Construction Control Measures

1. Delivered materials or excavated material shall not be placed in the flow-line.
2. Keep materials out of the rain. Store materials under cover, with temporary roofs or plastic sheets so that they are protected from rainfall, runoff, run-on, and wind. Store all material away from creeks and storm drain inlets. Cover stockpiles (road base, excavated material, etc.) and other materials with plastic tarps to protect from rain. Use berms and curb socks around the entire stockpile to prevent run-on and runoff.
3. Sweep and remove materials from surfaces that drain to storm drain inlets, creeks, or other state waters, throughout the workday. Increase the frequency of the sweeping when precipitation is in the forecast.
4. Make sure portable toilets are in good working order. Check frequently for leaks and service regularly.
5. Designate one area for parking, equipment and vehicle refueling, and routine maintenance. The designated area should be well away from gutters, storm drain inlets, and state waters.
6. Maintain all vehicles and heavy equipment. Inspect frequently for leaks and repair as necessary.
7. Major equipment or vehicle repairs and washings shall not occur on site.
8. Clean up leaks, drips, and other spills immediately.
9. Never hose down dirty pavement or surfaces. Clean up all spills and leaks using dry methods (with absorbent materials and/or rags). If spills occur on dirt areas, dig up and remove contaminated soil and dispose of properly.
10. Catch drips from paving equipment with drip pans, absorbent material (cloth, rags, etc.) heavy cardboard, or plywood placed under the machine when not in use.
11. After breaking up old pavement and concrete, remove all chunks and pieces to avoid contact with rainfall and runoff.
12. When making saw-cuts in pavement (asphalt or concrete), use as little water as possible. The County prohibits saw cut slurry from entering a storm drain inlet or state water. Cover each storm drain inlet per the inlet protection detail during saw operation and contain the slurry. After the liquid evaporates, shovel or vacuum the slurry residue from the pavement or gutter and remove it from the site.
13. Do not discharge any concrete, slurry or rinse water into street, flow line, storm drains, or drainage channels from concrete activities and concrete pumping equipment.
14. Completely sweep the streets immediately following milling operations. Use a hand broom to clean up all areas that are not accessible to the street sweeper.
15. The water from the concrete flow line sections that have been removed, left open and have collected rain/irrigation must be discharged in accordance with Colorado's dewatering general permit (<https://cdphe.colorado.gov/dewatering-general-permit-program>) and the County's stormwater dewatering control measure in the GESC Standard Notes and Details.
16. Diesel fuel shall not be used to lubricate equipment parts.
17. Concrete curing compound or tack oil shall not be sprayed if rain is in the forecast.

Appendix C—Oil and Gas Construction Activity in Unincorporated Arapahoe County Outside of the SEMSWA Service Area

Oil & Gas Construction Activity in Unincorporated Arapahoe County Outside of the SEMSWA Service Area

The requirements presented in this section apply to oil and gas developments in unincorporated Arapahoe County's (County's) municipal separate storm sewer system (MS4) permit boundaries and outside of the Southeast Metro Stormwater Authority (SEMSWA) service area. These requirements are in addition to the grading, erosion, and sediment control (GESC) permit requirements in the County's *GESC Manual*. Erosion and sediment control permits, formerly known as Low-Impact GESC permits, are not applicable to oil and gas construction activities.

A GESC permit must be issued for oil and gas construction activities that disturb 1 acre or more, or less than 1 acre, but are part of a larger common plan of development or sale that disturbs 1 acre or more. The GESC permit must be issued prior to beginning any grading for the purpose of oil and gas development. Two types of GESC permits can be issued for oil and gas construction activity—a standard GESC permit and a field-wide GESC permit. The submittal requirements for a GESC permit for oil and gas construction activity are the same as outlined in the County's *GESC Manual*, except for the following:

1. GESC Plan Checklist
 - a. The Final GESC Drawing shall include the following additional information:
 - i. Location of permanent improvements such as well heads, tanks, etc.
 - ii. Location and limit of production area.
2. The GESC Standard Notes and Details shall include the following additional notes:
 - a. At sites where the Oil and Gas Company or its contractor is not the site owner or operator, i.e. where proposed construction sites overlap existing construction sites, the Oil and Gas Company or its contractor must comply with the provision of the County GESC and the State of Colorado Stormwater Management Plan for the project their construction activities will impact. The Oil and Gas Company or its contractor must ensure that their activities do not render ineffective the erosion and sediment control measures for the site. Should the Oil and Gas Company or its contractor damage or render ineffective any control measures for the site, the Oil and Gas Company or its contractor will repair or replace the control measures affected. The Oil and Gas Company or its contractor will be responsible for control measures that includes seed or sod and must provide maintenance, including any watering necessary to ensure that establishment of the sod or seed.
 - b. The Oil and Gas Company or its contractor is required to provide street sweeping of paved roadways and other control measures as necessary to ensure that sediments, resulting from their activity, do not enter the stormwater system, during or following construction. The street shall be swept throughout the day and at the end of each working day at minimum, but if tracking is identified, sweeping must be implemented immediately and continue until such time that tracking is no longer identified as a potential pollutant source.
 - c. The use of hoses and water to flush or wash any material into any stormwater facility is prohibited.
 - d. The Oil and Gas Company or its contractor must practice good housekeeping practices. This includes proper storage of hazardous material, waste disposal,

equipment and material storage, fueling procedures, spill response and material recovery.

3. Approved land use document(s).

Field Wide GESC Permit Requirements

For multiple (two or more) projects that are similar in nature and where construction will occur within a 2-year period, the County will use a field wide review process for oil and gas well operations, pipeline connections, and midstream construction that replaces the GESC Narrative Template review. This review process will streamline the GESC permitting process for those projects that are consistent and repetitive, and performed by vetted companies that will be constructing multiple projects.

The field wide GESC documents differ from the standard oil and gas GESC documents with the addition of a total project area map, example site plans, and a different report. The field wide GESC plans provide example site plans for the various working conditions (e.g., pad on cut area, pad on fill area, pad crossing multiple sections, and access roads grading encroached into floodplain). The field wide GESC report revises the overall costs by taking an average unit cost per acre in lieu of determining collateral based on the total control measures proposed.

The Field Wide GESC report and example site plans and are valid for a period of 2 years from the date of County approval.

To begin construction or land disturbing activities on an individual project site, as shown in the approved field wide GESC total project area map, a site-specific standard GESC permit shall be required along with individual site GESC plans. Individual site GESC plans shall be provided conforming to the approved field wide GESC plans for the various working conditions. The field wide GESC narrative template shall be used for each individual project and an individual site GESC narrative template is not required.

Appendix D–GESC Plan Checklist

Grading, Erosion, and Sediment Control (GESC) Plan Checklist

This checklist must be completed, signed, and submitted with the GESC Plan.

Erosion and sediment Control (ESC) Permits do not require this checklist

GESC Plan shall be a stand-alone document and not included in the Construction Drawings

Yes	No	N/A	GESC Requirement
			GESC PLAN COVER SHEET
			Name or Project/Site Name.
			Project Address.
			Owner Contact Information (Name, Company, Address, Phone).
			Engineer Contact Information (Name, Company, Address, Phone).
			Plan Sheet Index.
			Case Number(s) in lower left-hand corner.
			The following notes:
			<p>GESC Design Engineer’s signature block with name, date, and Professional Engineer registration number. Signature blocks shall include the following certification statement: “I hereby attest that this Grading, Erosion, and Sediment Control (GESC) document for <i>[insert development name]</i> has been prepared by me or under my direct supervision, and to the best of my knowledge and ability has been prepared in accordance with the latest version of the GESC Manual. The signature and stamp affixed hereon certifies that this GESC document was prepared in accordance with the required regulations and criteria; however, the stamp and signature does not certify or guarantee future performance of the execution of the plan by the operator. The operator is responsible for executing the construction work according to the information set forth in the plan and in accordance with all applicable requirements.”</p> <p>Registered Professional Engineer _____ State of Colorado No. _____ Affix with Seal with Date</p>
			<p>Owner or authorized agent acknowledgement of the GESC review and acceptance of GESC responsibility by including the following certification statement: “I hereby certify that additional control measures may be required of the permittee if the plan does not function as intended. The requirements of this GESC document shall run with the land and be the obligation of the owner until such time as the plan is completed, modified, or voided”</p> <p>Owner or authorized agent _____ Signature _____ Date _____</p>

Yes	No	N/A	GESC Requirement
			Approval Block 4.5" x 5.5".
			<p data-bbox="500 300 818 321">Arapahoe County Approval Block</p> <div data-bbox="485 348 837 779" style="border: 1px solid black; padding: 10px; margin: 10px auto; width: fit-content;"> <p data-bbox="561 684 761 701" style="text-align: center;">Engineering Services Division</p> <p data-bbox="500 705 813 764" style="text-align: center;">These plans have been reviewed and approved by Arapahoe County for Grading, Erosion, and Sediment Control improvements only.</p> </div>
			<p data-bbox="456 789 1325 890">General Location Map (non-copy written images or proper attribution included) at a scale of 1-inch to 1000-feet to 8000-feet, indicating:</p> <ol data-bbox="505 911 1065 1052" style="list-style-type: none"> 1. General vicinity of the site and location. 2. Major roadway names. 3. North arrow. 4. Scale.
			GESC DRAWING INDEX SHEET
			<p data-bbox="456 1108 1429 1245">For projects that require multiple plan-view sheets to adequately show the project area (based on a scale of 1" = 100' or larger), a single plan-view sheet shall be provided at a scale appropriate to show the entire site on one sheet.</p> <p data-bbox="456 1255 1352 1318">Areas of coverage of the multiple blow-up sheets are to be indicated as rectangles on the index sheet.</p>
			<p data-bbox="769 1325 1105 1350" style="text-align: center;">INITIAL GESC DRAWING</p> <p data-bbox="488 1360 1385 1423" style="text-align: center;">This plan sheet shall show Control Measures for the initial clearing, grubbing and preparation of a project. At a minimum it shall contain:</p>
			Property lines.
			Jurisdictional boundaries.
			<p data-bbox="456 1539 1127 1564">Existing topography at 1 or 2-foot contour intervals.</p> <p data-bbox="456 1572 1352 1675">Unless infeasible, contour intervals shall extend a minimum of 100-feet beyond the property line of the limits of construction if the project goes beyond property lines.</p>
			Existing and proposed easements.
			Labeled location of any existing structures or hydraulic features within the mapping boundary.
			Flow arrows that show stormwater flow directions on and off site.
			North arrow.

Yes	No	N/A	GESC Requirement
			Scale.
			Approval Block.
			Limits of construction encompassing all areas of work access points, storage and staging areas, borrow areas, stockpiles, construction trailer, utility tie-in locations, and floodplain or other environmentally sensitive areas within the limits of construction.
			Stream corridors, floodplains, and other Environmentally Sensitive Areas shall be shaded to show that those areas may not be disturbed, unless otherwise approved by the County.
			Location of active construction stockpiles, including topsoil, imported aggregates, and excess material.
			Location or storage and staging areas for equipment, equipment maintenance, fuel, lubricant, chemical (and other materials) and waste storage.
			Location of borrow or disposal areas.
			Location of temporary roads, including haul routes.
			Location, map symbol, and letter callouts of all initial control measures.
			Location, map symbols, and letter callouts of vehicle tracking controls (VTC.)
			Location, map symbols, and letter callouts of concrete washout area(s) (CWA).
			Location, map symbol, and letter callouts of dedicated asphalt and concrete batch plants.
			Location or other areas of operations where spills can occur. Refer to Section 6 of the <i>GESC Manual</i> .
			Information to be specified for each control measure, such as type and dimension called for in Section 8 of the <i>GESC Manual</i> .
			INTERIM GESC DRAWING This plan sheet shall show control measures during the grading, site construction, and revegetation process. At a minimum it shall contain:
			Existing topography and location of all existing control measures on the site, as shown on the Initial GESC Plan shall be screened/shaded back. Dimensions and quantity information for initial stage control measures should not be shown.

Yes	No	N/A	GESC Requirement
			Proposed topography at 1- or 2-foot contour intervals. Unless infeasible, contour intervals shall extend a minimum of 100-feet beyond the property line of the Limits of Construction if the project goes beyond property lines.
			Outlines of cut and fill areas and the summary of cut and fill volumes. Separate cut/fill sheets is permissible.
			Location, map symbol, and letter callouts of all interim control measures, including applicable control Measures implemented in the initial phase.
			Location, map symbols, and letter callouts of any anticipated stormwater dewatering (DW) activities. Note that dewatering is covered by a CDPS permit issued by CDPHE-WQCD. If this permit is anticipated, include the following note: "Location of CDPS Construction Dewatering activities must be updated by the permittee on the GESC plan and permitting occurs and prior to dewatering activity."
			Location of all improvements, drainage features and facilities, and other permanent features to be constructed in connection with, or as a part of, the proposed work, per the approved land use plan.
			Information to be specified for each control measure, such as type and dimension called for in Section 8 of the GESC Manual.
			FINAL GESC DRAWING This plan sheet shall show control measures at the completion of site construction through the final stabilization stage. At a minimum it shall contain:
			Only final contours shall be shown.
			Flow arrows that show stormwater flow direction on and off site, including all drainage features.
			Location of all final phase control measures, including applicable control measures implemented in the initial and/or interim phase, permanent landscaping, and any control measures necessary to minimize the movement of sediment off site until permanent vegetation can be established.
			Information to be specified for each Control Measure, such as type and dimension called for in Section 8 of the GESC Manual.
			OIL AND GAS ONLY: Location of permanent improvements such as well heads, tanks, etc.
			OIL AND GAS ONLY: Location and limit of production area.
			GESC NARRATIVE SHEET
			Completed GESC Narrative Sheets shall be included in each set of GESC plans.

			GESC STANDARD NOTES AND DETAILS
			A copy of the GESC Plan Standard Notes and Details shall be included in each set of GESC plans.

GESC Design Engineer Name:

Signature:

Date:

Appendix E–GESC Narrative Template

PROJECT DESCRIPTION

Project description (proposed land use), nature of construction at site, and proposed schedule

Total area of the site (acres)

Total area of the limits of construction (acres)

Total area of expected land disturbance (acres)

Project location (latitude and longitude at the expected main entrance to site)

EXISTING SITE CONDITIONS

Describe the existing topography, drainage patterns, and the percent cover from native vegetation on the site if the site is undisturbed, or the percent cover from native vegetation in a similar, local undisturbed area or adequate reference area if the site is disturbed. Include the methodology for determining the percentage and include reference photos on Sheet 2.

STORMWATER MANAGEMENT CONSIDERATIONS

Description of the general flow direction and where or how the discharge leaves the Limits of Construction, including a description of the immediate conveyance or area receiving the discharge and the receiving water(s) of the discharge, if different than the immediate conveyance or area receiving the discharge. If the stormwater discharge is to a municipal separate storm sewer system, include the name of the entity owning that system, the location(s) of the stormwater discharge, and the receiving water(s).

Description of how stormwater runoff from and through the site will be handled during construction.

SOILS

Discuss distinct types of soil anticipated on the site considering NRCS soil types and visual clues such as prior site disturbance and quality of vegetation

Topsoil testing results for agronomic parameters including texture, salts, organic matter, pH, and nutrients by an agronomic soils testing laboratory (onsite and import). Sites that will be stabilized independent of seed or have less than 1,000 square feet of proposed seed areas may be exempt from the topsoil quality analysis requirements.

Per Table 7.1 in the GESC Manual, characterize the suitability of the topsoil. Unsuitable topsoil is not adequate for use. Quantify topsoil from other areas of the site that have no unsuitable parameters or import of adequate topsoil.

For organic matter or nutrients found to be marginal based on test results, propose amendments to change the quality from marginal to suitable or ideal. Quantify topsoil from other areas of the site that have no unsuitable parameters or import of adequate topsoil.

FINAL STABILIZATION

Discuss permanent stabilization (buildings, pavement or hardscape, sod, seeding, landscaping, etc.)

CONTROL MEASURES

Discuss for each of the following pollutant sources what structural and/or non-structural control measures will be selected, designed, installed, implemented, and maintained.

Land disturbance and storage of soils

Vehicle tracking

Loading and unloading operations

Outdoor storage of construction site materials, building materials, fertilizers, and chemicals

Bulk storage of materials

Vehicle and equipment maintenance and fueling

Significant dust or particle generating processes

Concrete truck/equipment washing, including the chute and associated fixtures and equipment

Dedicated asphalt and concrete batch plants

Other areas or operations where spills can occur and management of contaminated soil

Routine maintenance activities involving fertilizers, pesticides, detergents, fuels, solvents, and oils

Other non-stormwater discharges including dewatering not covered by a CDPS permit and wash water that may contribute to pollutants. Non-industrial waste sources (portable toilets, worker trash)? Note proposed use of CDPHE-WQCD Low Risk Discharge Guidance Policy.

Other potential pollutants

UTILITY NOTIFICATION CENTER
OF COLORADO
CALL BEFORE YOU DIG
811
Call 2 days prior to any digging, grading or
excavating for the marking of underground
member utilities

ARAPAHOE COUNTY
PUBLIC WORKS & DEVELOPMENT
6924 S. LIMA STREET
CENTENNIAL, CO 80112



**GRADING, EROSION, AND SEDIMENT
CONTROL (GESC) NARRATIVE SHEET**
Page 1 of 2

SEED MIX

Seed mix (if different from County standard seed mix)

CALCULATIONS AND SIZING

Please provide the applicable calculations noted as necessary in the GESC Manual and Standard Notes and Details, including the following:

- Cut Back Curb (CBC) - required length, width and depth of sediment storage for disturbed tributary area.
- Check Dam (CD) - required length, crest length, and depth
- Diversion Ditch (DD) - longitudinal slope, minimum width, depth, and if DD is lined or unlined based on site conditions to include flow, longitudinal slope, soil type
- Erosion Control Blanket (ECB) - sized for the shear stress from a 2-year return period event for site conditions expected during the operation of the matting
- Reinforced Check Dam (RCD) - required length, crest length, and depth
- Sediment Basin (SB) - orifice hole diameter and number of holes, overflow crest length, bottom length and width, pipe diameter
- Sediment Trap (ST) - length and width
- Slope Intercept Ditch (SID) - depth
- Temporary Stream Crossing (TSC) - length, crest length, crossing height, number of pipes and diameter, type of pipe
- Vehicle Tracking Control (VTC) - length, if less than 50-feet

CALCULATIONS AND SIZING (CONT.)

PHOTOS

Include existing site conditions reference photos below for areas where final stabilization is vegetation.



Appendix F–GESC or ESC Standard Notes and Details

GRADING, EROSION, AND SEDIMENT CONTROL (GESC) GENERAL NOTES

- The Arapahoe County (County) signature affixed to this document indicates that the County has reviewed the document and found it in general compliance with the Grading, Erosion and Sediment Control (GESC) Manual. The County, through acceptance of this document, assumes no responsibility (other than as stated above) for the completeness and/or accuracy of these documents.
- The adequacy of the GESC plan lies with the design engineer. Changes to design intent that meet the definition of major modifications must be approved by the design engineer and the County. See Note 10.
- The GESC or ESC Plan shall be considered valid for two (2) years from the date of plan approval by the County, after which time the plan shall be void and will be subject to re-review and re-approval by the County. Plans must conform to current requirements and shall meet good engineering, hydrologic and pollution control practices. Plans with issued GESC or ESC permits remain valid until GESC or ESC permit final close out, except in cases when the County revokes the GESC or ESC permit.
- Refer to construction plans for implementation of all permanent improvements, including post-construction control measures. Coordinate with the County for timing of installation of post-construction control measures.
- All materials and workmanship shall be subject to inspection by the County. The County reserves the right to accept or reject any such materials and workmanship that does not conform to the GESC Manual; GESC or ESC Plan; GESC or ESC Permit; or good engineering, hydrologic and pollution control practices.
- Appropriate control measures must be implemented prior to the start of a land disturbance activity, must control potential pollutants during each phase of construction, and must be continued through final stabilization. Appropriate structural and non-structural control measures must be maintained in operational condition.
- Control measures must be selected, designed, installed, implemented, and maintained to provide control of all potential pollutants.
- The placement of control measures shall be in accordance with the accepted GESC or ESC plan and GESC Manual.
- Any variation in material, type or location of control measures from the County-approved GESC or ESC plan will require approval from the County.
- The approved GESC plan may require changes or alterations after acceptance to meet the changing site or project conditions or to address insufficiencies in design or installation.
 - Minor modifications generally include modifications that do not increase the scope or change hydrology of the site, but modify/improve specific control measures in use at a site. Minor modifications include control measure substitutions for other measures that are equivalent in performance and/or are more suitable to specific site conditions, relocation of previously approved control measures within the limits of construction, or changes to control measures based on the phasing of the site. If alternative control measures will be used, control measure specifications must be submitted to and approved by the County.

The GESC permittee shall obtain prior approval for major modifications from the design engineer and approval from the County for any proposed changes. Major modifications to a GESC Plan are those involving re-engineering or changes to site hydrology and are not considered minor modifications. Control measures that may be classified as a major modification are indicated with a "box" surrounding the control measure acronym, as indicated on the legend, (this sheet, right). The permittee must update the GESC Plan as necessary to reflect site conditions for all modifications.

- After the County's signature and stamping of the GESC or ESC Plan, the permittee shall install non-earth disturbing initial-stage control measures indicated on the approved GESC or ESC plan. The permittee shall refer to the legend for initial non-earth disturbing control measures to be installed prior to the pre-construction meeting and initial inspection. If the installation of the non-earth disturbing initial-stage control measures are not approved by the County at the preconstruction meeting, the applicant may be required to pay a reinspection fee, address any problems with the control measure installation, and call to reschedule the preconstruction meeting and initial inspection. Construction activity may commence after permit issuance following a passing initial inspection.
- The County and GESC manager are required to attend the preconstruction meeting. In addition, the following representatives should attend the preconstruction meeting: general contractor, owner or owner's representative, alternate GESC manager, grading subcontractor, and control measure contractor and/or inspector.
- The permittee shall refer to the legend for earth-disturbing initial-stage control measures, such as sediment basins, sediment traps, and diversion ditches. Earth-disturbing initial-stage control measures shall be installed as soon as feasible after permit issuance.
- The GESC manager shall be on site as necessary to ensure the GESC plan and GESC permit requirements are being implemented and shall provide the County with contact information, including email and phone. In the event the GESC manager (or alternate GESC manager) cannot be reached within 24 hours, and a noncompliance has or may occur, a violation may be assessed. Notification shall be provided to the County if the GESC manager or alternate change.
- All construction traffic must exit the site through the County-approved access point. A vehicle tracking control pad or other stabilized surface approved by the County is required at all exit points on the site. Additional stabilized construction entrances may be added if approved by the County. It is the GESC or ESC permittee's responsibility to obtain any other approvals necessary to utilize additional access points.
- No recycled asphalt or concrete shall be used as a part of a control measure or for new or improved access roads within the limits of construction.
- The GESC or ESC permittee is responsible for cleanup of sediment, mud, or construction materials tracked onto paved areas. Paved areas including streets, sidewalks, and other impervious areas are to be kept clean throughout construction activity and shall be cleaned immediately with a street sweeper or similar device. Street washing is not allowed. The County reserves the right to require additional control measures to ensure streets are kept free of sediment, mud, or construction materials. Tracking outside of the limits of construction is not acceptable, is a violation of the GESC Permit, and can be enforced by the County.
- Accepted control measures shall be inspected and maintained in accordance with the GESC Manual, GESC or ESC plan, and GESC or ESC permit and kept in good repair for the duration of the project. All necessary maintenance and repair activities shall be completed immediately by the permittee.
- Straw bales are not permitted for use as a control measure.
- Appropriately store, cover, and/or isolate onsite potential construction-associated waste pollutants to prevent runoff of pollutants and contamination of groundwater. Portable toilets shall be anchored or positioned in a manner to prevent spilling and runoff of pollutants.
- The GESC or ESC permittee shall adhere to the accepted limits of construction. The County must approve any changes to the limits of construction, and at the County's discretion, additional control measures may be required in any additional areas of construction activity. The GESC or ESC permittee shall be held responsible for obtaining permission and restoration for work offsite.
- Significant dust or particulate-generating processes shall be minimized. Wind erosion shall be minimized during earthwork operations and control measures utilized as necessary to minimize dust from earthwork equipment and wind.
- Soils that will be stockpiled and remain inactive for more than thirty (30) days shall be stabilized within fourteen (14) days of stockpile construction. The permittee shall maximize the distance of active construction stockpiles from the floodplain. Active construction stockpiles shall not be placed within a floodplain unless accepted by the County. Reworking the disturbed area within the thirty (30) days for the sole purpose of avoiding the requirement to stabilize the exposed area shall not be considered an acceptable practice.
- Topsoil shall be stripped and stockpiled in the location shown on the accepted GESC Plan and in accordance with the GESC Narrative Sheet, unless otherwise accepted by the County.
- For spills that are an emergency, call 911. It is the responsibility of the GESC or ESC permittee to report any spills in accordance with federal, state, and local regulations. This includes any discharge of pollutants to State waters which shall be reported to the CDPHE-WQCD at 1-877-518-5608. All spills that impact the MS4 or State waters must be reported to the County at 720-874-6500. Failure to report spills to the County or failure to fully remediate any spills may result in enforcement.
- The cleaning of concrete delivery truck chutes is restricted to approved concrete washout locations. The discharge of water containing waste concrete offsite or to the MS4 is prohibited. All concrete waste shall be properly cleaned up and disposed of at an appropriate location.
- All dewatering onsite is the responsibility of the GESC or ESC permittee. All dewatering operations must not cause erosion or negatively impact the site. Any impacts that occur will be the responsibility of the GESC or ESC permittee to repair. For dewatering that requires a CDPHE-WQCD dewatering general permit, the permittee is responsible for obtaining and complying with the applicable permits.
- For projects that have a Public Improvement Permit (PIP) and/or Floodplain Permit, separate inspections will be conducted by the County to ensure compliance with applicable criteria outside of the GESC program.
- Hydraulic seeding is not an acceptable method of seeding.
- Importing or exporting excess fill dirt within the County area may require a GESC or ESC permit for the secondary site.

- All areas disturbed by construction and soil stockpiles shall be stabilized as soon as possible to reduce the duration of soil exposure to runoff events and the potential for erosion. All disturbed areas which are either final graded or will remain inactive for a period of more than thirty (30) days, shall be required to be stabilized within fourteen (14) days of the completion of the grading activities. Acceptable temporary stabilization control measures are as follows:
 - Surface roughening.
 - Seeding and mulching (temporary seed mix may only be used if area is inactive for 6 months or less unless otherwise approved by the County).
 - Erosion control blanket with or without seed.
 - Hydromulch.
 - Tarps (for stockpile areas).

Acceptable final stabilization control measures are as follows:

- Seeding and mulching.
 - Erosion control blanket with seed.
 - Hydromulch with seed, as approved by the County.
 - Permanent hardscape including but not limited to concrete and pavement.
 - Sod or landscaping according to accepted landscape plans.
- Prior to the initial close-out inspection, the following must be completed:
 - All streets, sidewalks and flowlines must be cleaned and generally free of sediment or debris.
 - Clean all inlets, trickle channels, and all other drainage features, as necessary.
 - Remove construction control measures (per the accepted GESC or ESC plan) and install and/or maintain final stabilization control measures per the approved GESC or ESC plan.
 - All stabilization control measures shall be installed and maintained in accordance with the approved GESC plan and the GESC Manual. Final stabilization is reached when construction activities at the site have been completed, permanent stabilization methods are complete, and temporary control measures are removed. Areas being stabilized with a vegetative cover must have evenly-distributed perennial vegetation. The vegetation coverage must be, at a minimum, equal to 70 percent of what would have been provided by native vegetation in a local, undisturbed area or adequate reference site. Note that it is the permittee's responsibility to control noxious weeds in accordance with local and state law, including List A Noxious Weeds which are required by the Colorado Department of Agriculture to be eradicated.
 - A copy of the permit and accepted plans must be available upon request, within the timeframe specified within the request.
 - For ESC permitted sites, refer to italicized notes.

GRADING, EROSION, AND SEDIMENT CONTROL (GESC) GENERAL NOTES - OIL AND GAS PROJECTS

The following notes apply to projects constructed under the Arapahoe County Land Development Code, Section 5-3.6 Use by Special Review - Oil and Gas Facilities:

- At sites where the Oil and Gas Company or its contractor is not the site owner or operator, i.e. where proposed construction sites overlap existing construction sites, the Oil and Gas Company or its contractor must comply with the provision of the County GESC and the State of Colorado Stormwater Management Plan for the project their construction activities will impact. The Oil and Gas Company or its contractor must ensure that their activities do not render ineffective the erosion and sediment control measures for the site. Should the Oil and Gas Company or its contractor damage or render ineffective any control measures for the site, the Oil and Gas Company or its contractor will repair or replace the control measures affected. The Oil and Gas Company or its contractor will be responsible for control measures that includes seed or sod and must provide maintenance, including any watering necessary to ensure that establishment of the sod or seed.
- The Oil and Gas Company or its contractor is required to provide street sweeping of paved roads and other control measures as necessary to ensure that sediments, resulting from their activity, do not enter the stormwater system, during or following construction. The street shall be swept throughout the day and at the end of each working day at minimum, but if tracking is identified, sweeping must be implemented immediately and continue until such time that tracking is no longer identified as a potential pollutant source.
- The use of hoses and water to flush or wash any material into any stormwater facility is prohibited.
- The Oil and Gas Company or its contractor must practice good housekeeping practices. This includes proper storage of hazardous material, waste disposal, equipment and material storage, fueling procedures, spill response and material recovery.

LEGEND			
1	(1)	CBC	CUT BACK CURB
2	(1)	CD	CHECK DAM
3	(1)	CWA	CONCRETE WASHOUT AREA
4	(1)	CF	CONSTRUCTION FENCE
5	(1)	CM	CONSTRUCTION MARKERS
6	(1)	CC	CURB CHECK
7	(1)	DW	DEWATERING
8	(2)	DD	DIVERSION DITCH
9	(2)	ECB	EROSION CONTROL BLANKET
10	(2)	GMS	GROUT MIXING STATION
11	(2)	IP	INLET PROTECTION
12	(2)	RFB	REINFORCED ROCK BERM
13	(2)	RRC	RRE FOR CULVERT PROTECTION
14	(3)	SB	SEDIMENT BASIN
15	(3)	SCL	SEDIMENT CONTROL LOG
16	(3)	ST	SEDIMENT TRAP
17	(3)	SM	SEEDING AND MULCHING
18	(3)	SF	SILT FENCE
19	(3)	SFR	SILT FENCE REINFORCED
20	(4)	SID	SLOPE INTERCEPT DITCH
21	(4)	SSA	STABILIZED STAGING AREA
22	(4)	SR	SURFACE ROUGHENING
23	(4)	TSI	TEMPORARY SLOPE DRAIN
24	(4)	TSC	TEMPORARY STREAM CROSSING
25	(4)	VTC	VEHICLE TRACKING CONTROL
26	(4)	WW	WTC WITH WHEEL WASH
		LOC	LIMITS OF CONSTRUCTION
		*EG	MAY MEET MAJOR MODIFICATION REQUIREMENTS

INITIAL CONTROL MEASURE
(NON-EARTH DISTURBING CONTROL MEASURES MUST BE INSTALLED PRIOR TO PERMIT ISSUANCE)

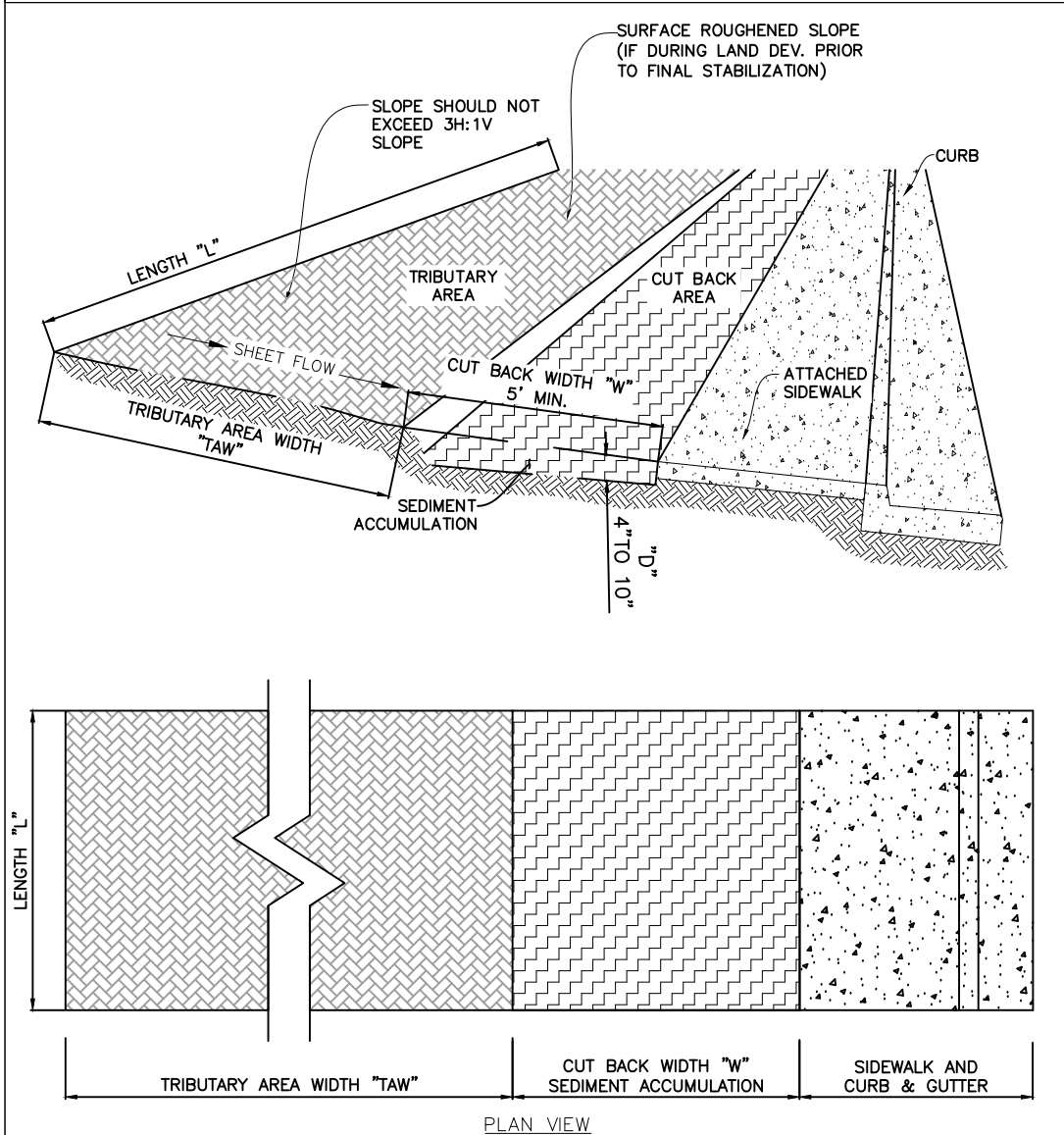

- INSTALLATION**
- SEE PLAN VIEW FOR:
 - LOCATIONS OF CHECK DAMS.
 - LENGTH, "L", CREST LENGTH, "CL", HEIGHT, "H", AND DEPTH, "D".
 - USE SURFACE ROUGHENING ON UPGRADIENT SLOPES IF DURING LAND DEVELOPMENT (IF PRIOR TO FINAL STABILIZATION).
 - CUT BACK CURB SHALL BE UTILIZED TO PROVIDE STORAGE VOLUME EQUAL TO 1800 CUBIC FEET PER UPSTREAM ACRE.
 - 5' WIDTH (W) AND 6" DEPTH (D) IS ACCEPTABLE FOR TRIBUTARY AREA WIDTHS UP TO 60'.

- INSPECTION AND MAINTENANCE**
- THE GESC PERMITTEE SHALL INSPECT AS NECESSARY TO ENSURE THE ADEQUACY AND FUNCTIONALITY OF THE CONTROL MEASURE.
 - REMOVE ACCUMULATED SEDIMENT WHEN 1/2 CAPACITY. DO NOT ALLOW SEDIMENT TO OVERFLOW ONTO CURB OR SIDEWALK.
 - IMPLEMENT ADDITIONAL CONTROL MEASURES SUCH AS DOWNGRADIENT SEDIMENT CONTROL LOGS, CURB CHECKS, OR OTHER BARRIERS AS ON-SITE CONDITIONS REQUIRE.



ROCK AND RIPRAP GRADATIONS

TABLE 1. RIPRAP GRADATIONS			
DESIGN STONE SIZE (INCHES)	% OF MATERIAL SMALLER THAN TYPICAL STONE	TYPICAL STONE EQUIVALENT DIAMETER (INCHES)	TYPICAL STONE WEIGHT (POUNDS)
6	70 - 100	12	95
	50 - 70	8	33
	2 - 10	6	0.4
9	70 - 100	15	160
	50 - 70	12	55
	2 - 10	9	1.3
12	70 - 100	21	440
	50 - 70	18	275
	2 - 10	12	65
18	100	30	1280
	50 - 70	24	650
	2 - 10	18	275
24	100	42	3500
	50 - 70	33	1700
	2 - 10	24	650

TABLE 2. RIPRAP BEDDING

SIETVE SIZE	MASS PERCENT PASSING SQUARE MESH SIEVES
	CLASS A
3"	100
1 1/2"	20 - 90
NO. 4	0 - 20
NO. 200	0 - 3

MATCHES SPECIFICATIONS FOR CDOT CLASS A FILTER MATERIAL AND MILE HIGH FLOOD DISTRICT TYPE 1 BEDDING. ALL ROCK SHALL BE FRACTURED FACE, ALL SIDES.

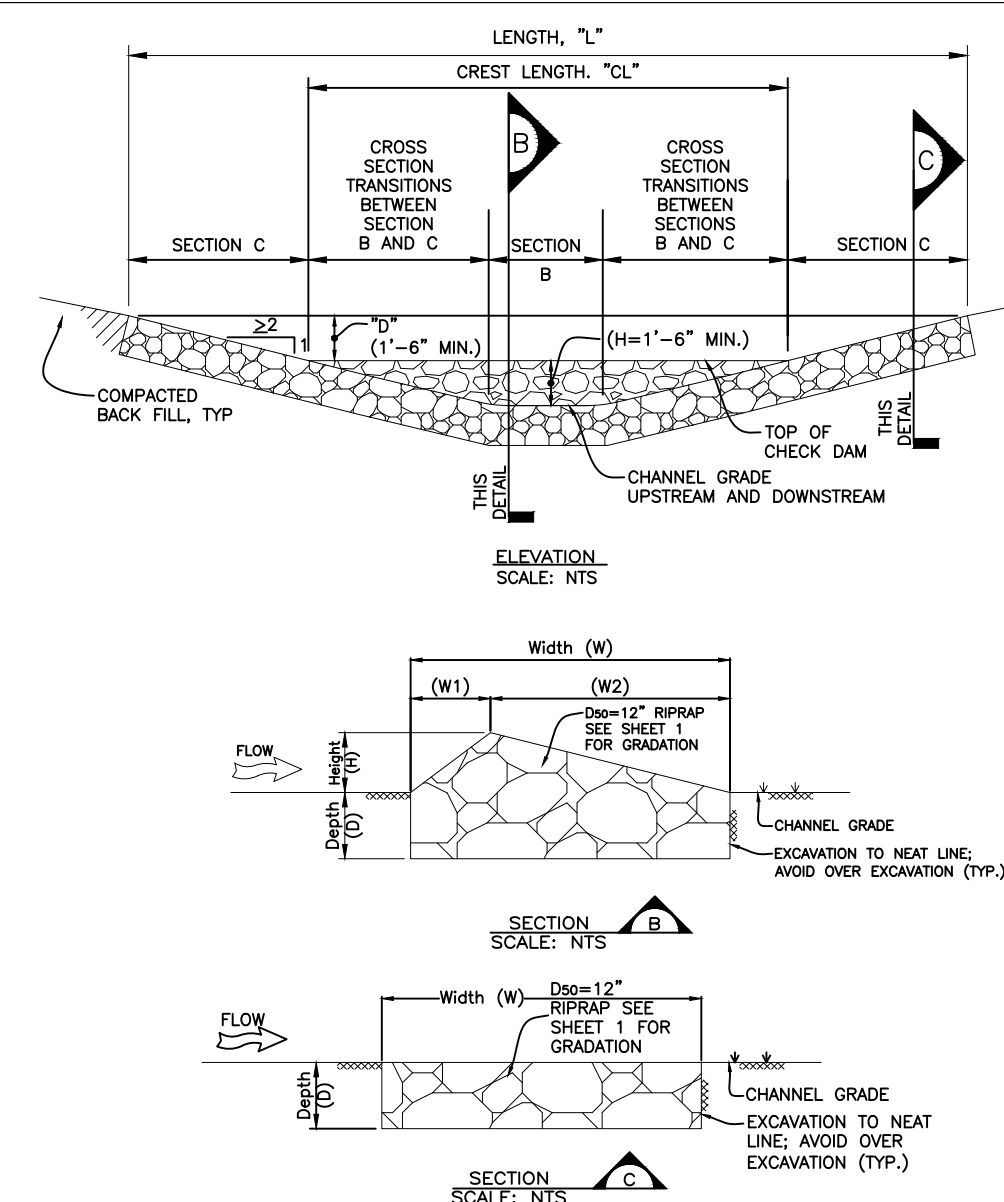

- CHECK DAM INSTALLATION NOTES**
- SEE PLAN VIEW FOR:
 - LOCATIONS OF CHECK DAMS.
 - LENGTH, "L", CREST LENGTH, "CL", HEIGHT, "H", AND DEPTH, "D".
 - CHECK DAMS INDICATED ON INITIAL GESC PLAN SHALL BE INSTALLED PRIOR TO ANY UPSTREAM LAND-DISTURBING ACTIVITIES.
 - VL RIPRAP SHALL BE UTILIZED FOR CHECK DAMS.
 - RIP RAP SHALL BE TRENCHED INTO THE CHANNEL BANKS TO ADEQUATELY ANCHOR WITH CENTER OF THE CHECK DAM LOWER TO ALLOW FOR OVERTOPPING AT THE CREST.

- CHECK DAM MAINTENANCE NOTES**
- SEDIMENT ACCUMULATED UPSTREAM OF CHECK DAMS SHALL BE REMOVED WHEN THE SEDIMENT DEPTH UPSTREAM OF CHECK DAM IS WITHIN 1/2 OF THE HEIGHT OF THE CREST.
 - CHECK DAMS ARE TO REMAIN IN PLACE UNTIL THE UPSTREAM DISTURBED AREA IS STABILIZED.
 - WHEN CHECK DAMS ARE REMOVED, EXCAVATIONS SHALL BE FILLED WITH SUITABLE COMPACTED BACK FILL. ANY DISTURBED AREA SHALL BE SEEDING AND MULCHED AND COVERED WITH EROSION CONTROL BLANKET OR OTHERWISE STABILIZED IN A MANNER APPROVED BY THE COUNTY.

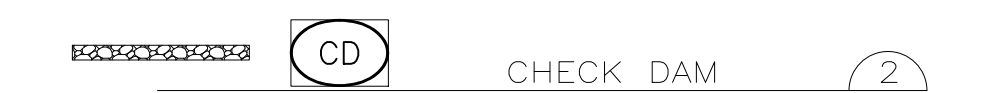

UTILITY NOTIFICATION CENTER OF COLORADO
CALL BEFORE YOU DIG
811
Call 2 days prior to any digging, grading or excavating for the marking of underground member utilities

ARAPAHOE COUNTY
PUBLIC WORKS AND DEVELOPMENT
6924 S. LIMA STREET
CENTENNIAL, CO 80112
720-874-6500

ARAPAHOE COUNTY

GRADING EROSION AND SEDIMENT CONTROL
STANDARD NOTES AND DETAILS
REVISED OCTOBER 2025

GESC
SHEET
1 OF 4

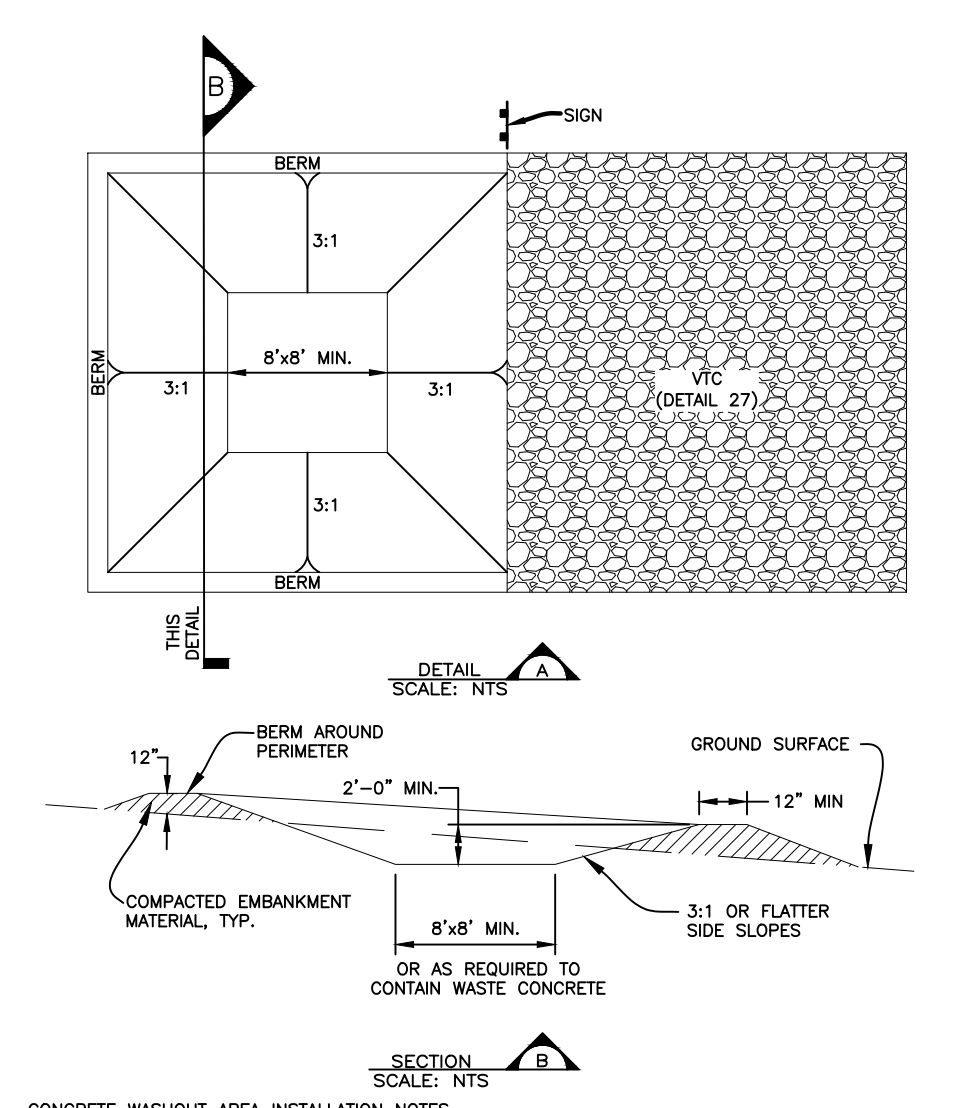

- CONCRETE WASHOUT AREA INSTALLATION NOTES**
1. THE CONCRETE WASHOUT AREA (CWA) AND/OR GROUT WASHOUT AREA (GWA) SHALL BE INSTALLED PRIOR TO ANY CONCRETE PLACEMENT ON SITE.
 2. VEHICLE TRACKING CONTROL (VTC) (DETAIL 27) IS REQUIRED AT THE ACCESS POINT. THE VTC CAN BE REMOVED AT THE DISCRETION OF THE COUNTY.
 3. SIGNAGE SHALL BE PLACED AT THE WASHOUT AREA, AND MAY BE ELSEWHERE AS NECESSARY TO CLEARLY INDICATE THE LOCATION OF THE CONCRETE WASHOUT AREA TO OPERATORS OF CONCRETE TRUCKS AND PUMP TRUCKS.
 4. COMPACTED EXCAVATED MATERIAL MAY BE UTILIZED IN PERIMETER BERM CONSTRUCTION.
 5. THE CWA/GWA SHALL BE LOCATED A MINIMUM OF 50 FEET FROM STORM DRAIN INLETS, OPEN CONVEYANCE CHANNELS, DRAINAGE FACILITIES AND WATERWAYS, UNLESS UNFEASIBLE.
 6. THE CWA/GWA MUST BE LINED IN AREAS WITH HIGH GROUNDWATER. LINERS MUST BE 30 MIL OR GREATER.
 7. THE CWA/GWA MUST BE LOCATED WITHIN THE LIMITS OF CONSTRUCTION.
- CONCRETE WASHOUT AREA MAINTENANCE NOTES**
1. THE CONCRETE WASHOUT AREA SHALL BE REPAIRED AND ENLARGED OR CLEANED OUT AS NECESSARY TO MAINTAIN CAPACITY FOR WASTED CONCRETE.
 2. AS NEEDED DURING CONSTRUCTION, AND AT THE END OF CONSTRUCTION, ALL CONCRETE SHALL BE REMOVED FROM THE SITE AND DISPOSED OF AT AN APPROVED WASTE SITE.
 3. WHEN THE CONCRETE WASHOUT AREA IS REMOVED, THE DISTURBED AREA SHALL BE DRILL SEEDED AND CRIMP MULCHED OR OTHERWISE STABILIZED IN A MANNER APPROVED BY THE COUNTY.
 4. CONCRETE WASHOUT AREA MUST BE EMPTIED OUT ONCE STORAGE AREA BECOMES 2/3 FULL, OR AS DETERMINED BY THE COUNTY INSPECTOR.

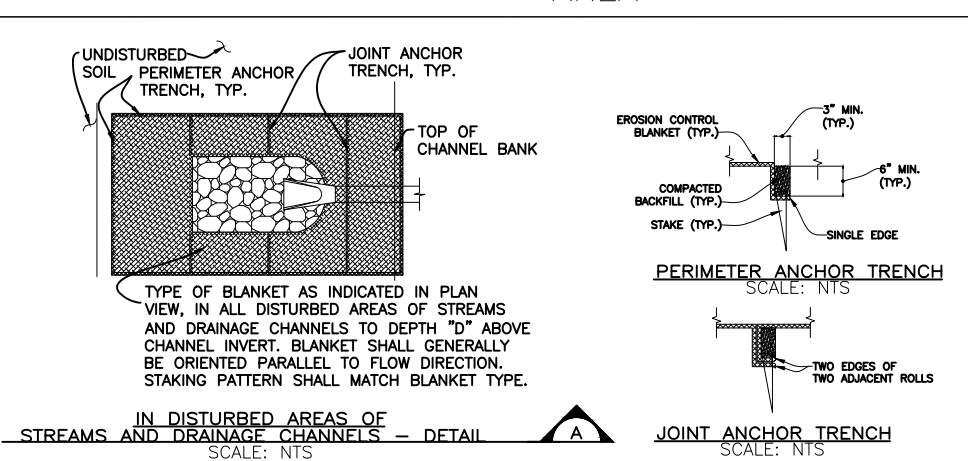

- EROSION CONTROL BLANKET INSTALLATION NOTES**
1. SEE PLAN VIEW FOR:
 - LOCATION OF PERIMETER OF EROSION CONTROL BLANKET.
 - TYPE OF BLANKET (STRAW, STRAW-COCOONUT, COCONUT, OR EXCELSIOR).
 - AREA "A" IN SQUARE YARDS OF EACH TYPE OF BLANKET.
 2. ALL EROSION CONTROL BLANKETS, STAKES, AND NETTING SHALL BE MADE OF 100% NATURAL AND BIODEGRADABLE MATERIAL. NO PLASTIC OR OTHER SYNTHETIC MATERIAL, INCLUDING PHOTO-DEGRADABLE, SHALL BE ALLOWED.
 3. IN AREAS WHERE EROSION CONTROL BLANKET IS SHOWN ON THE PLANS, THE PERMITTEE SHALL PLACE TOPSOIL OR AMENDED SOIL AND PERFORM FINAL GRADING, SURFACE PREPARATION, AND SEEDING BELOW THE BLANKET IN ACCORDANCE WITH THE REQUIREMENTS OF DETAIL 19, SEEDING AND MULCHING. SUBGRADE SHALL BE SMOOTH PRIOR TO BLANKET INSTALLATION AND THE BLANKET SHALL BE IN FULL CONTACT WITH SUBGRADE. NO GAPS OR VOIDS SHALL EXIST UNDER THE BLANKET.
 4. PERIMETER ANCHOR TRENCH SHALL BE USED AT OUTSIDE PERIMETER OF ALL BLANKET AREAS. FOLLOW ALL MANUFACTURER'S INSTALLATION SPECIFICATIONS.
 5. INTERMEDIATE ANCHOR TRENCH SHALL BE USED AT SPACING OF ONE-HALF THE ROLL LENGTH FOR COCONUT AND EXCELSIOR BLANKETS.
 6. MATERIAL SPECIFICATIONS OF EROSION CONTROL BLANKET SHALL CONFORM TO TABLE 7.1.
 7. SEEDING AND MULCHING DISTURBED IN THE PROCESS OF INSTALLING EROSION CONTROL BLANKET SHALL BE RESEEDED AND MULCHED IN ACCORDANCE WITH DETAIL 19.
 8. SEE DRAINAGE DESIGN PLANS FOR MAJOR DRAINAGEWAY STABILIZATION MEASURES THAT MAY EXCEED THE DESIGN CONDITIONS ASSOCIATED WITH THE DETAILS ABOVE.
 9. IF USING ECB FOR TEMPORARY STABILIZATION, UTILIZE THESE INSTALLATION NOTES WITH THE EXCEPTION OF FINAL GRADING, TOPSOIL, AND SEEDING.
- | TYPE | COCONUT CONTENT | STRAW CONTENT | EXCELSIOR CONTENT | NETTING MIN. |
|----------------|-----------------|---------------|-------------------|----------------|
| STRAW* | - | 100% | - | DOUBLE/NATURAL |
| STRAW-COCOONUT | 30% MIN. | 70% MAX. | - | DOUBLE/NATURAL |
| COCONUT | 100% | - | - | DOUBLE/NATURAL |
| EXCELSIOR | - | - | 100% | DOUBLE/NATURAL |
- * FOR OUTSIDE OF STREAMS AND DRAINAGE CHANNELS
- EROSION CONTROL BLANKET MAINTENANCE NOTES**
1. THE GESC PERMITTEE SHALL INSPECT AS NECESSARY TO ENSURE THE ADEQUACY AND FUNCTIONALITY OF THE CONTROL MEASURE.
 2. EROSION CONTROL BLANKET IS TO BE LEFT IN PLACE UNLESS REQUESTED TO BE ACCEPTED FOR REMOVAL BY THE COUNTY.
 3. ANY EROSION CONTROL BLANKET PULLED OUT, TORN, OR OTHERWISE DAMAGED SHALL BE RE-INSTALLED, ANY SUBGRADE AREAS BELOW THE BLANKET THAT HAVE ERODED TO CREATE A VOID UNDER THE BLANKET, OR THAT REMAIN DEEP OF GRASS SHALL BE REPAIRED, RESEEDED AND MULCHED AND THE EROSION CONTROL BLANKET REINSTALLED.
 4. REMOVAL OF 2X4 WEDGE STAKES SHALL BE REQUIRED PRIOR TO FINAL CLOSE OUT OF THE GESC PERMIT.
 5. EOD-STAKES MAY BE USED IN AREAS ABOVE ORDINARY HIGH WATER MARK.

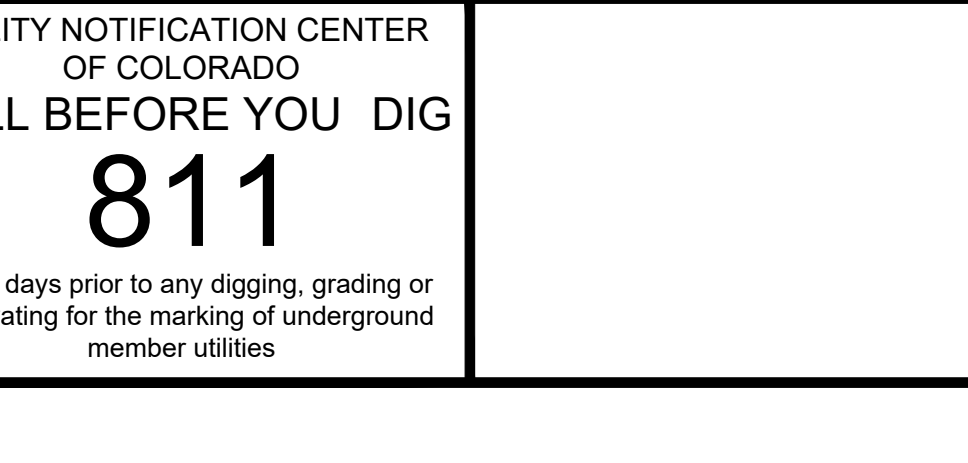

UTILITY NOTIFICATION CENTER OF COLORADO
CALL BEFORE YOU DIG
811
 Call 2 days prior to any digging, grading or excavating for the marking of underground member utilities

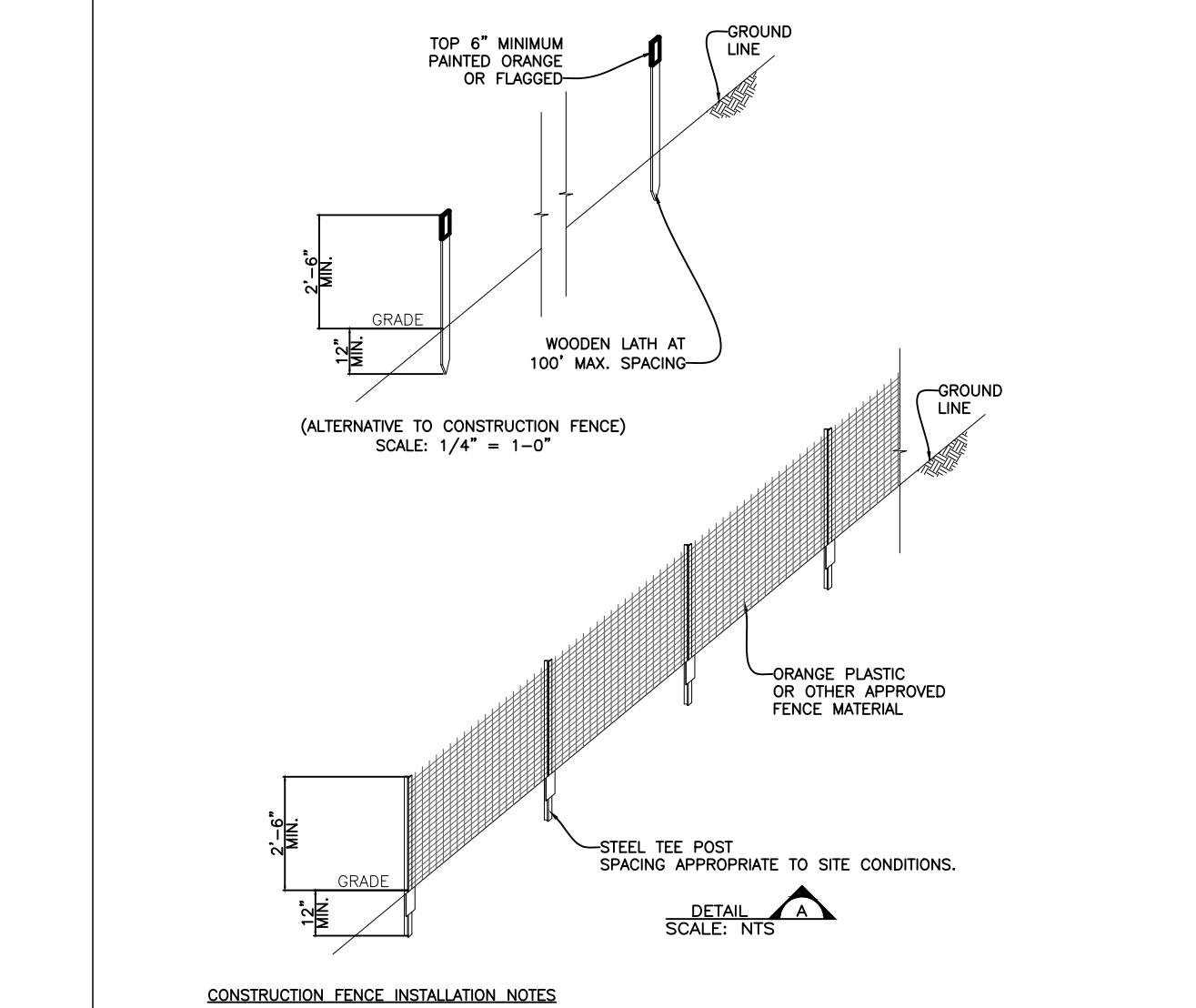

- CONSTRUCTION FENCE INSTALLATION NOTES**
1. SEE PLAN VIEW FOR:
 - TYPE OF CONSTRUCTION LIMIT INDICATOR (FENCE OR MARKERS).
 - LOCATION AND LENGTH OF FENCE OR LINE OF MARKERS.
 2. CONSTRUCTION FENCE OR MARKERS INDICATED ON INITIAL GESC PLAN SHALL BE INSTALLED PRIOR TO OTHER CONTROL MEASURES AND ANY LAND-RESTRICTING ACTIVITIES.
 3. STEEL TEE POSTS SHALL BE UTILIZED FOR SUPPORT OF CONSTRUCTION FENCE. SPACING OF TEE POSTS SHALL BE APPROPRIATE TO SITE CONDITIONS.
- CONSTRUCTION FENCE MAINTENANCE NOTES**
1. FENCE OR MARKERS SHALL BE REMOVED AT THE END OF CONSTRUCTION, IF ANY DISTURBED AREA EXISTS AFTER FENCE REMOVAL, IT SHALL BE DRILL SEEDED AND CRIMP MULCHED OR OTHERWISE STABILIZED IN A MANNER APPROVED BY THE COUNTY.

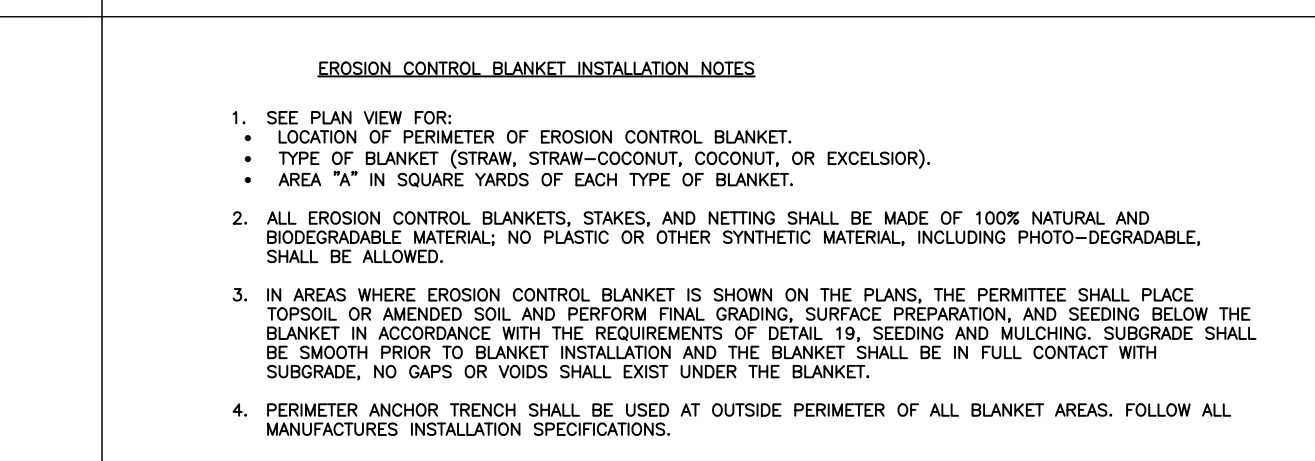

- CONSTRUCTION FENCE MAINTENANCE NOTES**
1. THE GESC PERMITTEE SHALL INSPECT AS NECESSARY TO ENSURE THE ADEQUACY AND FUNCTIONALITY OF THE CONTROL MEASURE.
 2. CONSTRUCTION FENCE IS TO BE LEFT IN PLACE UNLESS REQUESTED TO BE ACCEPTED FOR REMOVAL BY THE COUNTY.

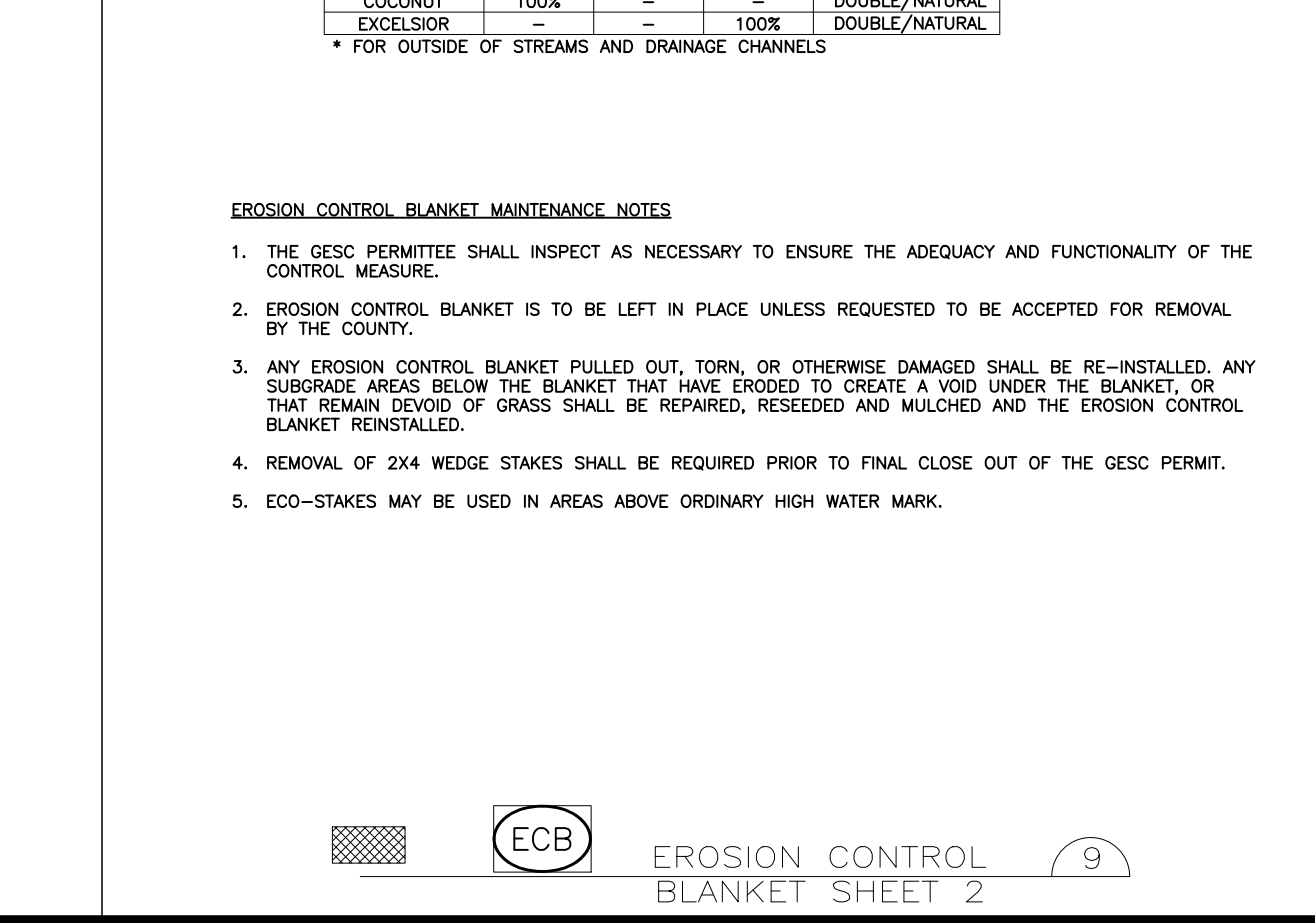

- CURB SOCK INSTALLATION NOTES**
1. ADDITIONAL CURB SOCKS MAY BE REQUIRED AS DIRECTED BY THE COUNTY.
 2. CURB SOCKS IN STREETS SHALL BE INSTALLED WITHIN 48-HOURS OF POURING CURBS. CURB SOCKS (AFTER PAVEMENT) SHALL BE INSTALLED WITHIN 48 HOURS AFTER PAVING IS PLACED.
 3. CRUSHED ROCK SHALL BE FRACTURED FACE ON ALL SIDES.
 4. WIRE MESH SHALL BE FABRICATED OF WIRE TWISTED INTO A MESH WITH A MAXIMUM OPENING OF 1.0 INCH (COMMONLY TERMED "CHICKEN WIRE"). ROLL WIDTH SHALL BE 48-INCHES.
 5. WIRE MESH SHALL BE SECURED USING "HOG RINGS" OR WIRE TIES AT APPROXIMATELY 6-INCH CENTERS ALONG ALL JOINTS AND AT APPROXIMATELY 2-INCH CENTERS ON ENDS OF CURB SOCK.
 6. REINFORCED ROCK BERM SHALL BE CONSTRUCTED IN ONE PIECE OR SHALL BE CONSTRUCTED USING JOINT DETAIL.
 7. THE TOP OF REINFORCED ROCK BERM SHALL BE 1/2"-1" BELOW TOP OF CURB.
- CURB SOCK MAINTENANCE NOTES**
1. SEDIMENT ACCUMULATED UPSTREAM OF CURB SOCK SHALL BE REMOVED WHEN THERE IS EVIDENCE OF SEDIMENT BUILDUP.
 2. CURB PROTECTION IS TO REMAIN IN PLACE UNTIL THE UPSTREAM DISTURBED AREA IS STABILIZED UNLESS THE COUNTY APPROVES EARLIER REMOVAL OF CURB PROTECTION IN STREETS.

ARAPAHOE COUNTY
 PUBLIC WORKS AND DEVELOPMENT
 6924 S. LIMA STREET
 CENTENNIAL, CO 80112
 720-874-6500

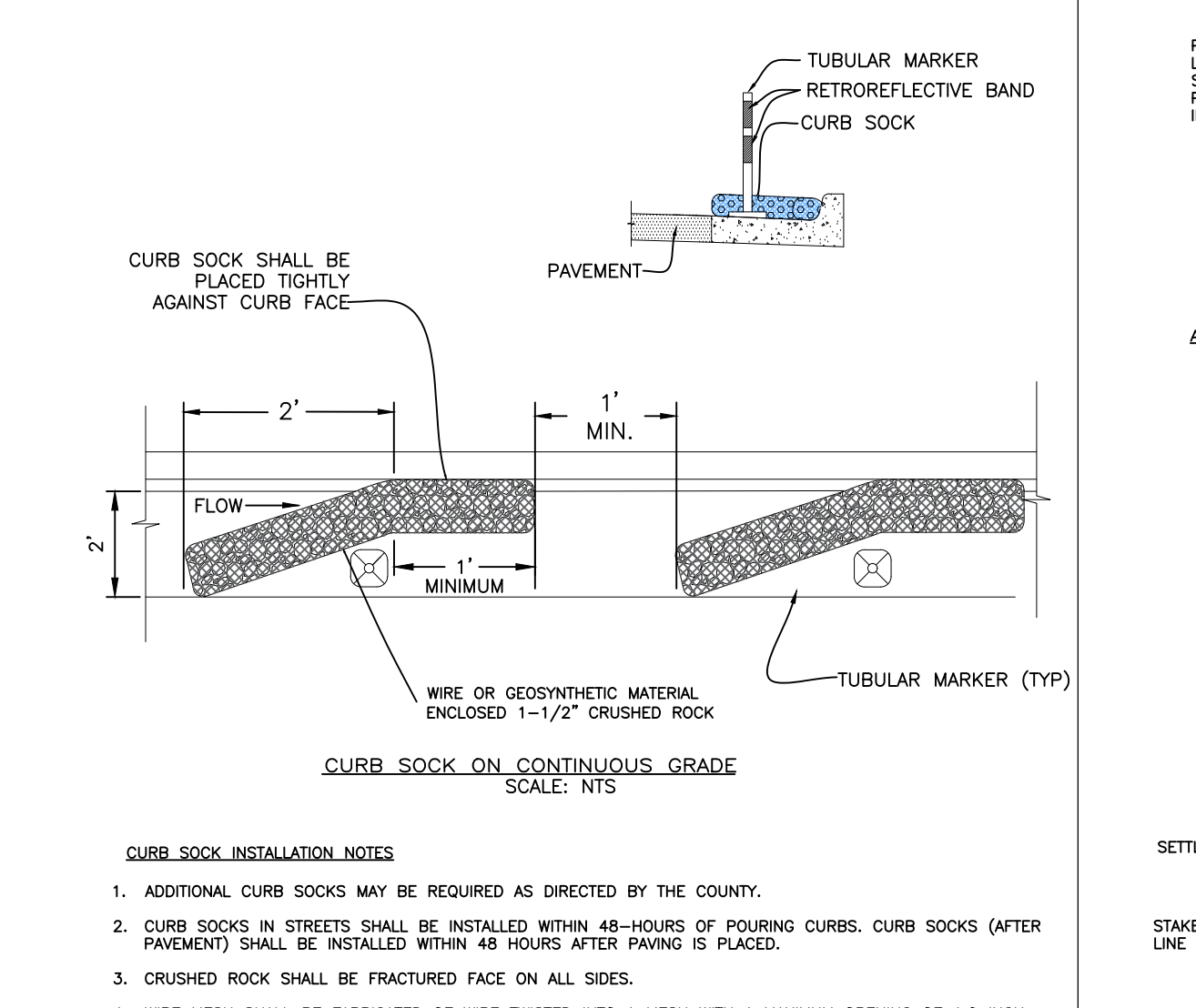

- CURB SOCK MAINTENANCE NOTES**
1. SEDIMENT ACCUMULATED UPSTREAM OF CURB SOCK SHALL BE REMOVED WHEN THERE IS EVIDENCE OF SEDIMENT BUILDUP.
 2. CURB PROTECTION IS TO REMAIN IN PLACE UNTIL THE UPSTREAM DISTURBED AREA IS STABILIZED UNLESS THE COUNTY APPROVES EARLIER REMOVAL OF CURB PROTECTION IN STREETS.

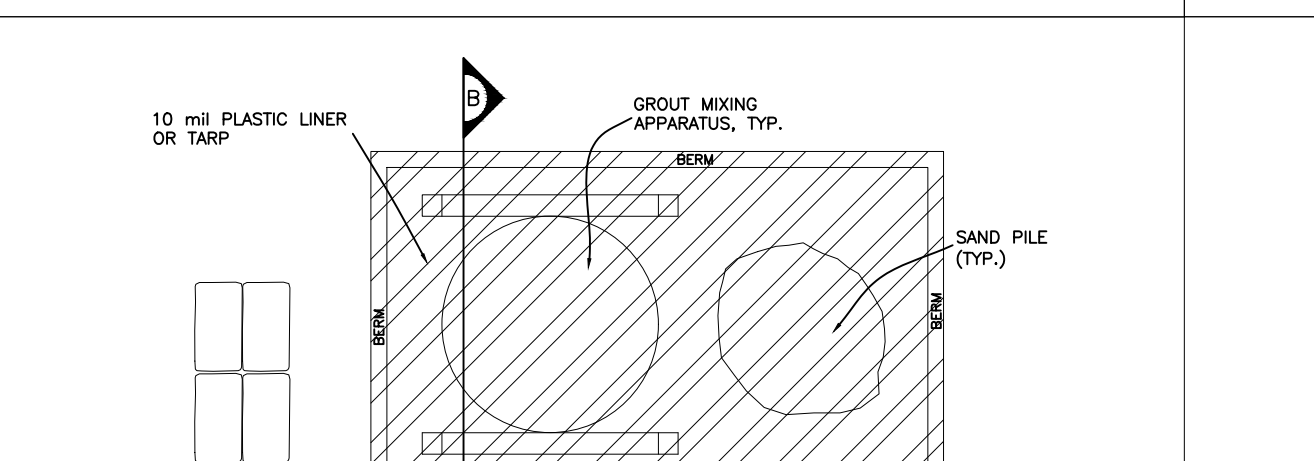

- STORMWATER DEWATERING**
1. THIS DETAIL APPLIES TO STORMWATER DEWATERING ONLY. FOR DEWATERING THAT REQUIRES A CDPE DEWATERING GENERAL PERMIT, THIS DETAIL SHALL NOT APPLY. IN THOSE INSTANCES, REFER TO APPLICABLE DEWATERING REQUIREMENTS.
 2. THE GESC PERMITTEE SHALL PROVIDE, OPERATE, AND MAINTAIN DEWATERING SYSTEMS OF SUFFICIENT SIZE AND CAPACITY.
 3. DEWATERING OPERATIONS SHALL USE ONE OR MORE OF THE DEWATERING SUMPS SHOWN ABOVE OR OTHER MEANS APPROVED BY THE COUNTY TO MINIMIZE THE PUMPING OF SEDIMENT.
 4. DISCHARGE POINT(S) SHALL BE A STABILIZED AREA.
 5. THE DISCHARGE END OF THE LINE SHALL BE STAKED IN PLACES TO PREVENT MOVEMENT OF THE LINE OFF THE STABILIZED DISCHARGE POINT.
 6. USE OF A SEDIMENT FILTER BAG MAY BE SUBSTITUTED FOR USE OF THE RIPRAP PAD AND SUMP DISCHARGE SETTLING BASIN. FILTER BAG TO SET ON RELATIVELY FLAT STABLE GROUND.

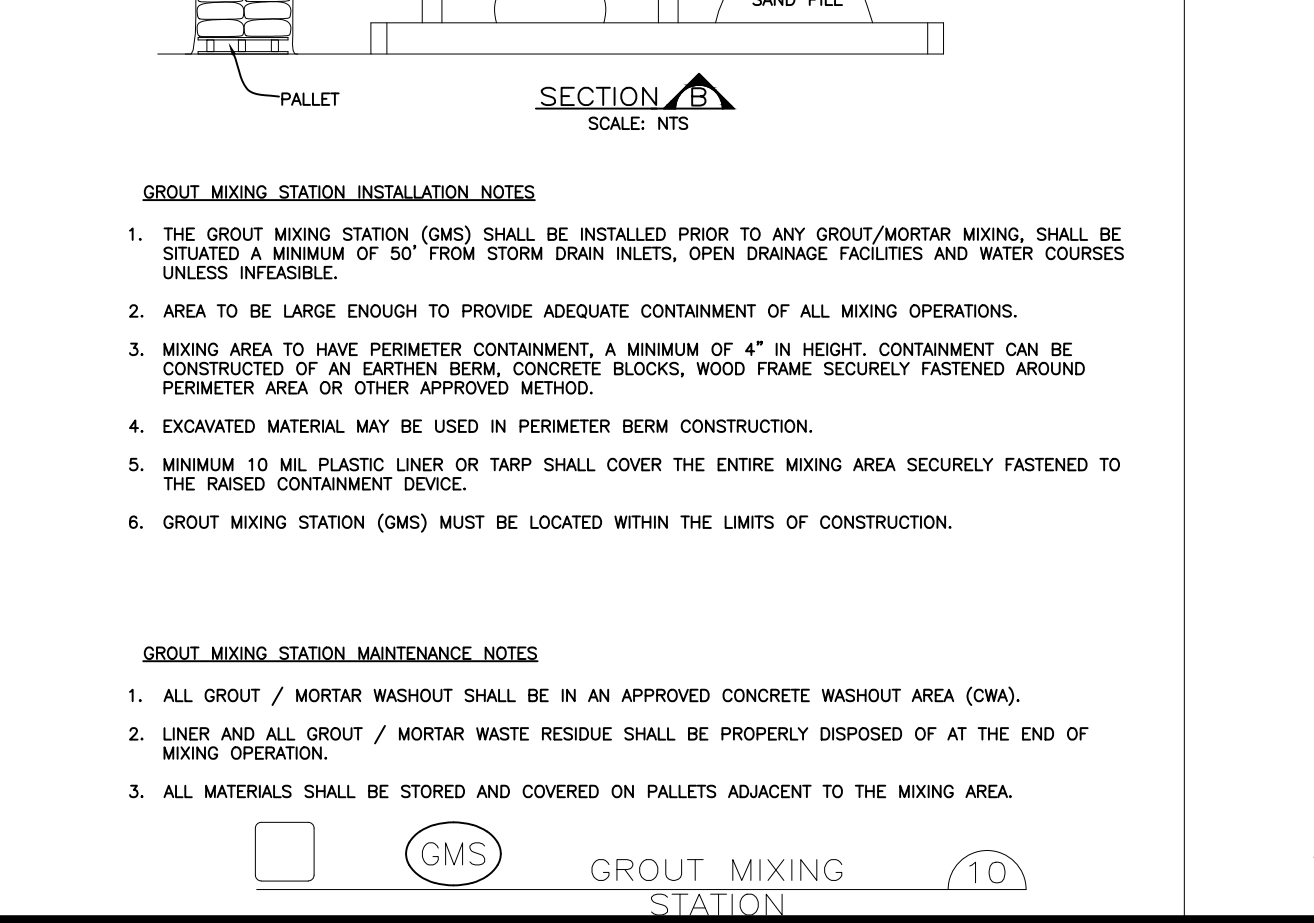

- GROUT MIXING STATION INSTALLATION NOTES**
1. THE GROUT MIXING STATION (GMS) SHALL BE INSTALLED PRIOR TO ANY GROUT/MORTAR MIXING. SHALL BE SITUATED A MINIMUM OF 50' FROM STORM DRAIN INLETS, OPEN DRAINAGE FACILITIES AND WATER COURSES UNLESS INFEASIBLE.
 2. AREA TO BE LARGE ENOUGH TO PROVIDE ADEQUATE CONTAINMENT OF ALL MIXING OPERATIONS.
 3. MIXING AREA TO HAVE PERIMETER CONTAINMENT. A MINIMUM OF 4" IN HEIGHT. CONTAINMENT CAN BE CONSTRUCTED OF AN EARTHEN BERM, CONCRETE BLOCKS, WOOD FRAME SECURELY FASTENED AROUND PERIMETER AREA OR OTHER APPROVED METHOD.
 4. EXCAVATED MATERIAL MAY BE USED IN PERIMETER BERM CONSTRUCTION.
 5. MINIMUM 10 MIL PLASTIC LINER OR TARP SHALL COVER THE ENTIRE MIXING AREA SECURELY FASTENED TO THE RAISED CONTAINMENT DEVICE.
 6. GROUT MIXING STATION (GMS) MUST BE LOCATED WITHIN THE LIMITS OF CONSTRUCTION.
- GROUT MIXING STATION MAINTENANCE NOTES**
1. ALL GROUT / MORTAR WASHOUT SHALL BE IN AN APPROVED CONCRETE WASHOUT AREA (CWA).
 2. LINER AND ALL GROUT / MORTAR WASTE RESIDUE SHALL BE PROPERLY DISPOSED OF AT THE END OF MIXING OPERATION.
 3. ALL MATERIALS SHALL BE STORED AND COVERED ON PALLETS ADJACENT TO THE MIXING AREA.

ARAPAHOE COUNTY

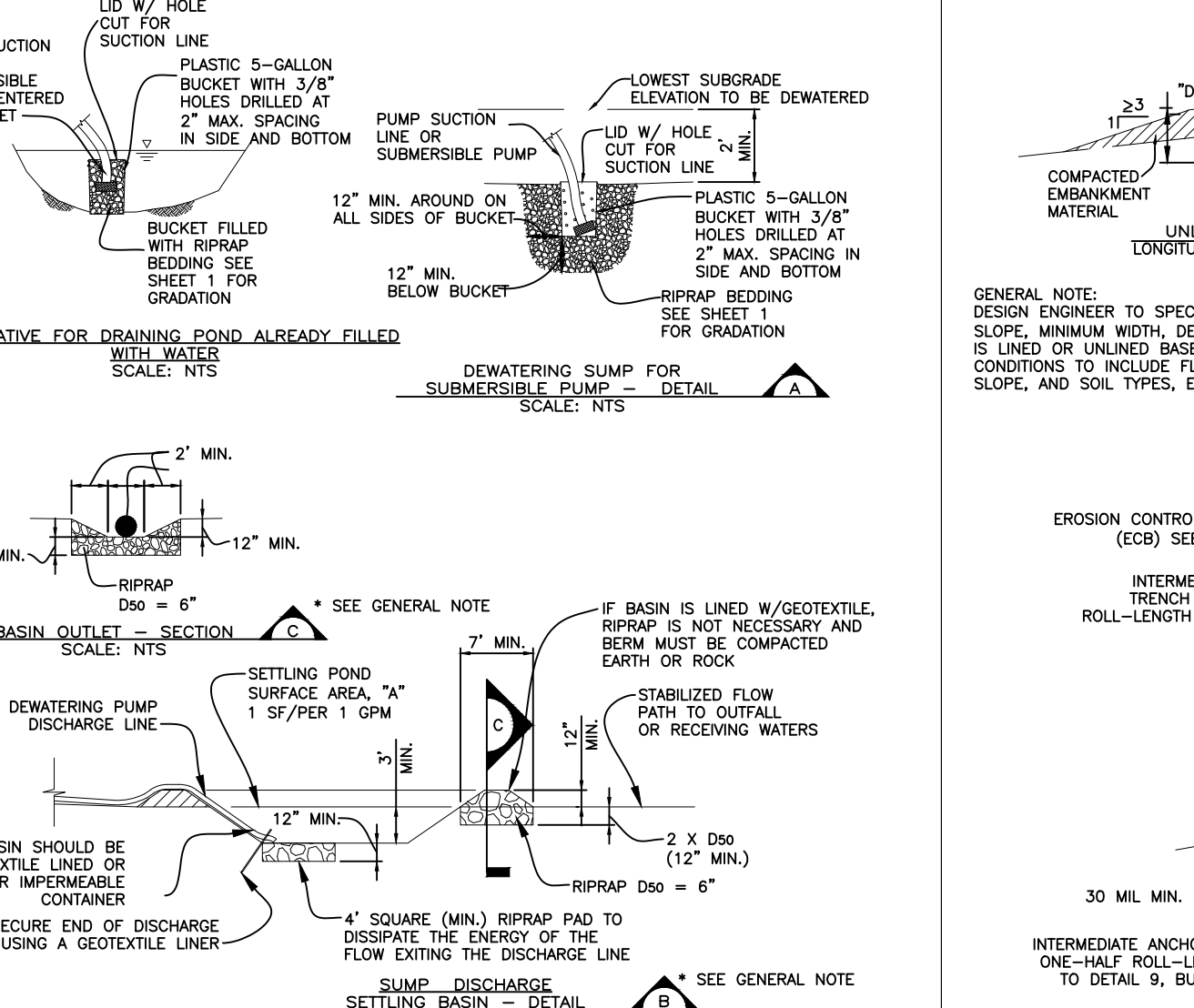

- INLET PROTECTION INSTALLATION NOTES**
1. INTERIM CONFIGURATION OF INLET PROTECTIONS SHALL BE INSTALLED WITHIN 48 HOURS OF POURING INLET. INLET PROTECTION (AFTER PAVEMENT) SHALL BE INSTALLED WITHIN 48 HOURS AFTER PAVING IS PLACED.
 2. INLET PROTECTION AT AREA INLETS SHALL BE INSTALLED WITHIN 48 HOURS AFTER POURING INLET.
 3. 1-1/2" CRUSHED ROCK SHALL BE FRACTURED FACE ON ALL SIDES.
 4. WIRE MESH SHALL BE FABRICATED OF WIRE TWISTED INTO A MESH WITH A MAXIMUM OPENING OF 1.0 INCH (COMMONLY TERMED "CHICKEN WIRE").
 5. WIRE MESH SHALL BE SECURED USING "HOG RINGS" OR WIRE TIES AT APPROXIMATELY 6-INCH CENTERS ALONG ALL JOINTS AND AT APPROXIMATELY 2-INCH CENTERS ON ENDS OF BERM.
 6. EXAMPLES OF ACCEPTABLE GEOSYNTHETIC MATERIAL: TENACITE MIRAFI® MIRAGRID 2XT; STRATA GLOBAL SOLUTIONS® STRATAGRID SG 150; SOLID FABRIC OPTIONAL.
 7. TUBULAR MARKERS SHALL BE PLACED ON EACH END OF THE INLET PROTECTION LOCATED ON STREETS WHERE PUBLIC ACCESS CAN OCCUR.
 8. THE TOP OF REINFORCED ROCK BERM SHALL ALLOW FOR OVERTOPPING INTO THE INLET.
 9. CRUSHED ROCK SHALL BE FRACTURED FACE (ALL SIDES) (1-1/2" MINUS). RECYCLED CONCRETE MAY NOT BE USED. NO GAPS SHALL EXIST BETWEEN SECTIONS OF REINFORCED ROCK BERMS. REINFORCED ROCK BERM OR CONCRETE BLOCK ENDS SHALL BE PLACED TIGHTLY AGAINST CURB FACE.
- INLET PROTECTION MAINTENANCE NOTES**
1. SEDIMENT ACCUMULATED UPSTREAM OF INLET PROTECTION SHALL BE REMOVED WHEN THERE IS A DEPTH OF NO MORE THAN 1/2 THE STORAGE CAPACITY OF THE INLET PROTECTION.
 2. INLET PROTECTION IS TO REMAIN IN PLACE UNTIL THE UPSTREAM DISTURBED AREA IS STABILIZED UNLESS THE COUNTY APPROVES EARLIER REMOVAL OF INLET PROTECTION IN STREETS.
 3. WHEN INLET PROTECTION AT AREA INLETS ARE REMOVED, THE DISTURBED AREA SHALL BE DRILL SEEDED AND CRIMP MULCHED OR OTHERWISE STABILIZED IN A MANNER APPROVED BY THE COUNTY.

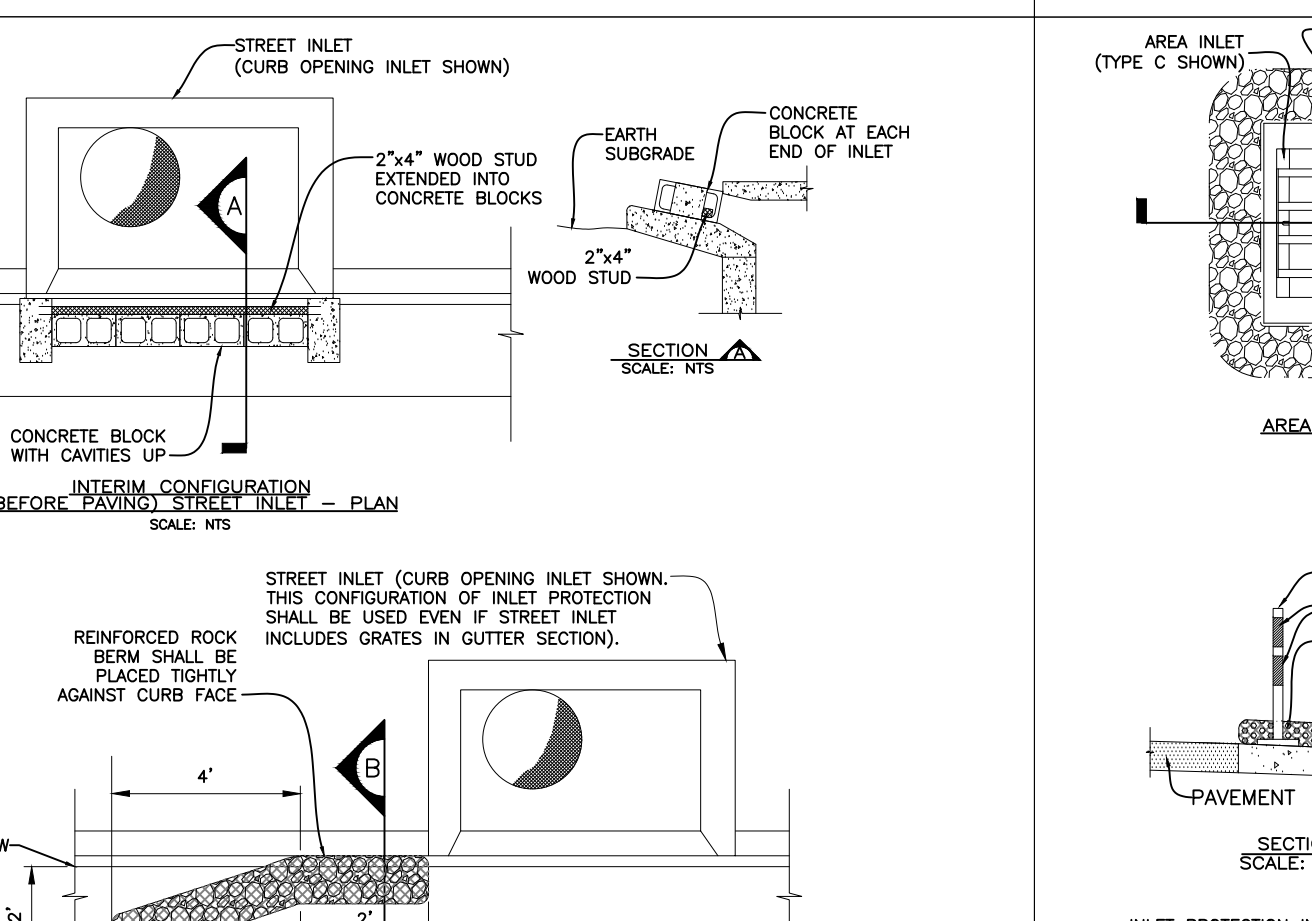

- INLET PROTECTION MAINTENANCE NOTES**
1. SEDIMENT ACCUMULATED UPSTREAM OF INLET PROTECTION SHALL BE REMOVED WHEN THERE IS A DEPTH OF NO MORE THAN 1/2 THE STORAGE CAPACITY OF THE INLET PROTECTION.
 2. INLET PROTECTION IS TO REMAIN IN PLACE UNTIL THE UPSTREAM DISTURBED AREA IS STABILIZED UNLESS THE COUNTY APPROVES EARLIER REMOVAL OF INLET PROTECTION IN STREETS.
 3. WHEN INLET PROTECTION AT AREA INLETS ARE REMOVED, THE DISTURBED AREA SHALL BE DRILL SEEDED AND CRIMP MULCHED OR OTHERWISE STABILIZED IN A MANNER APPROVED BY THE COUNTY.

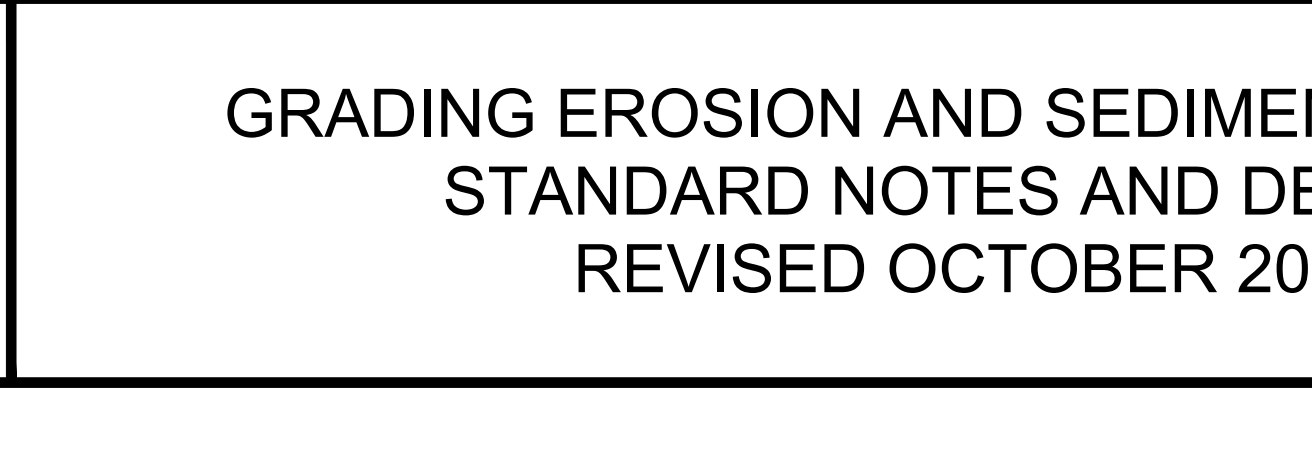

GRADING EROSION AND SEDIMENT CONTROL
 STANDARD NOTES AND DETAILS
 REVISED OCTOBER 2025

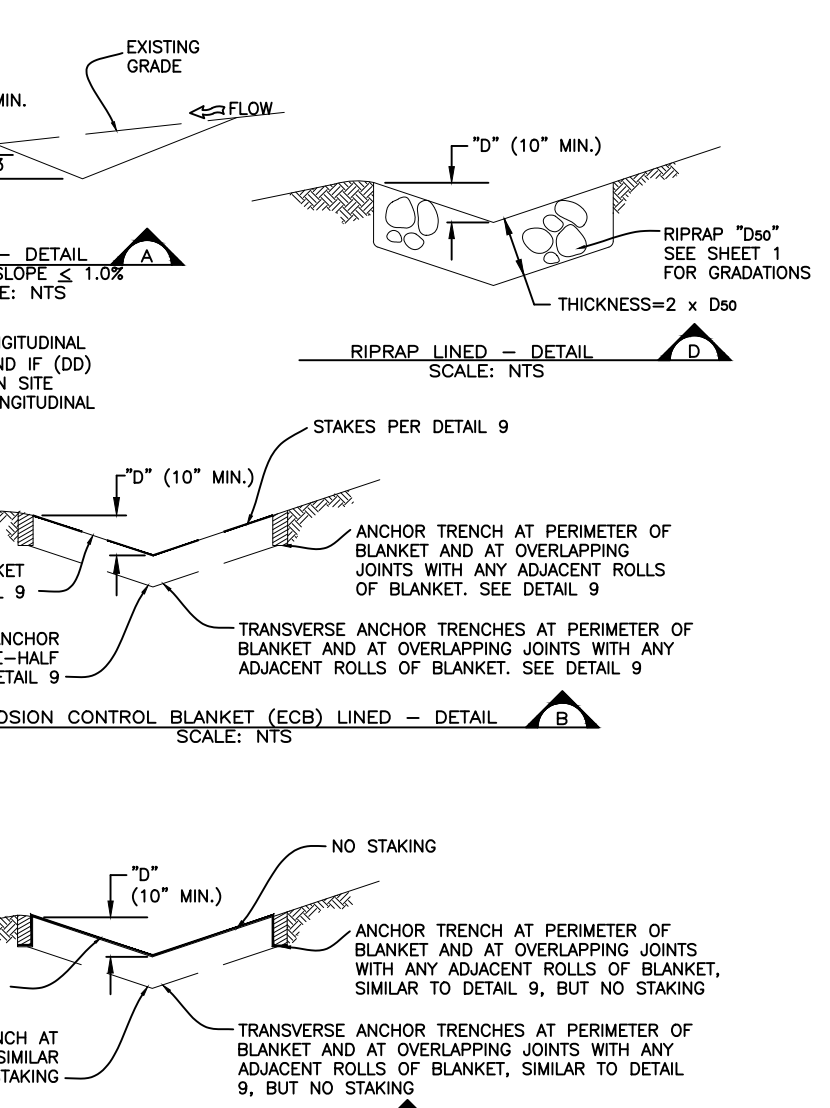

- DIVERSION DITCH INSTALLATION NOTES**
1. SEE PLAN VIEW FOR:
 - LOCATION OF DIVERSION DITCH.
 - TYPE OF DITCH (UNLINED, ECB LINED, PLASTIC LINED OR RIPRAP LINED).
 - LENGTH OF EACH TYPE OF DITCH.
 - DEPTH, "D", AND WIDTH, "W", DIMENSIONS.
 - FOR ECB LINED DITCH, EROSION CONTROL BLANKET TYPE (SEE DETAIL 9).
 - FOR RIPRAP LINED DITCH, SIZE OF RIPRAP, "D60".
 2. DIVERSION DITCHES INDICATED ON INITIAL GESC PLAN SHALL BE INSTALLED PRIOR TO ANY OTHER LAND-RESTRICTING ACTIVITIES.
 3. MINIMIZE AREAS WHERE VEHICULAR CROSSINGS OF DD WILL OCCUR. WHERE NOT FEASIBLE, THE GESC PERMITTEE SHALL INSTALL AN APPROPRIATELY SIZED TEMPORARY CULVERT OR COUNTY-APPROVED EQUIVALENT.
- DIVERSION DITCH MAINTENANCE NOTES**
1. DIVERSION DITCHES ARE TO REMAIN IN PLACE UNTIL PERMANENT STORMWATER CONVEYANCE IS CONSTRUCTED OR ADEQUATE ALTERNATIVE CMS ARE IMPLEMENTED, AS APPROVED BY THE COUNTY.

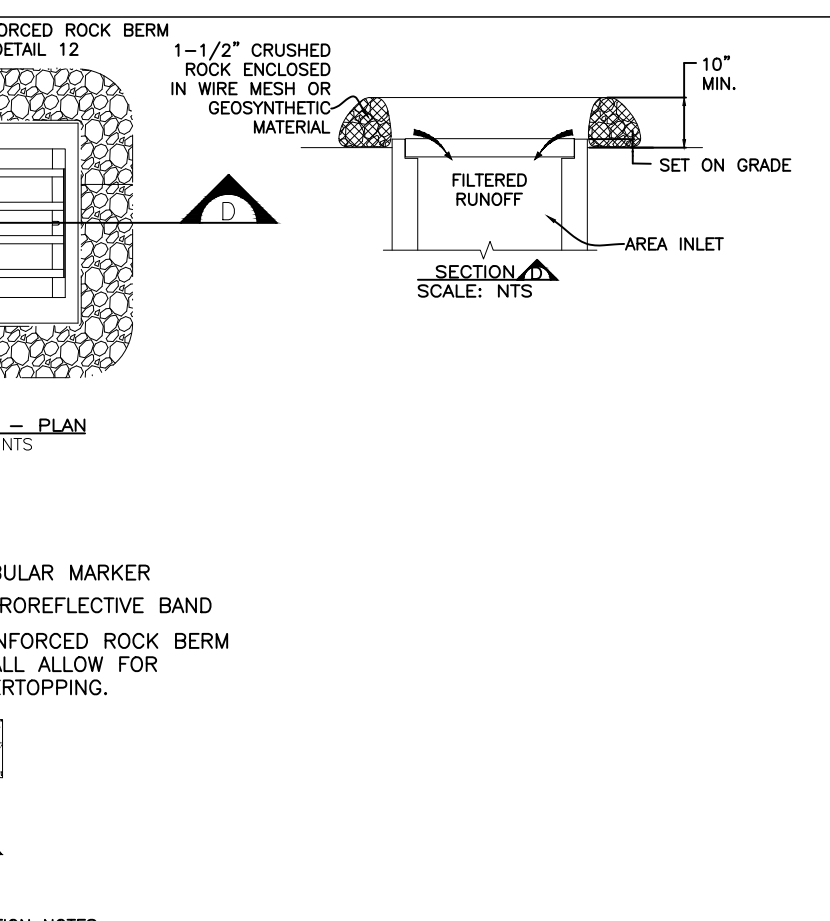

- DIVERSION DITCH MAINTENANCE NOTES**
1. DIVERSION DITCHES ARE TO REMAIN IN PLACE UNTIL PERMANENT STORMWATER CONVEYANCE IS CONSTRUCTED OR ADEQUATE ALTERNATIVE CMS ARE IMPLEMENTED, AS APPROVED BY THE COUNTY.

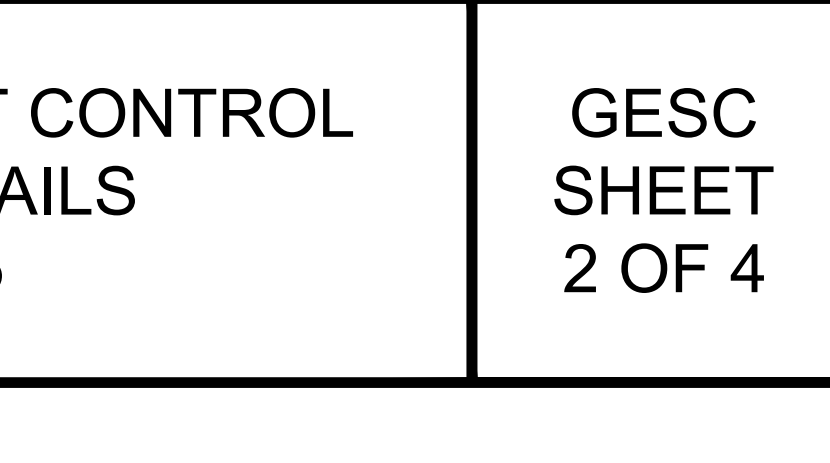

ARAPAHOE COUNTY

GESC SHEET 2 OF 4

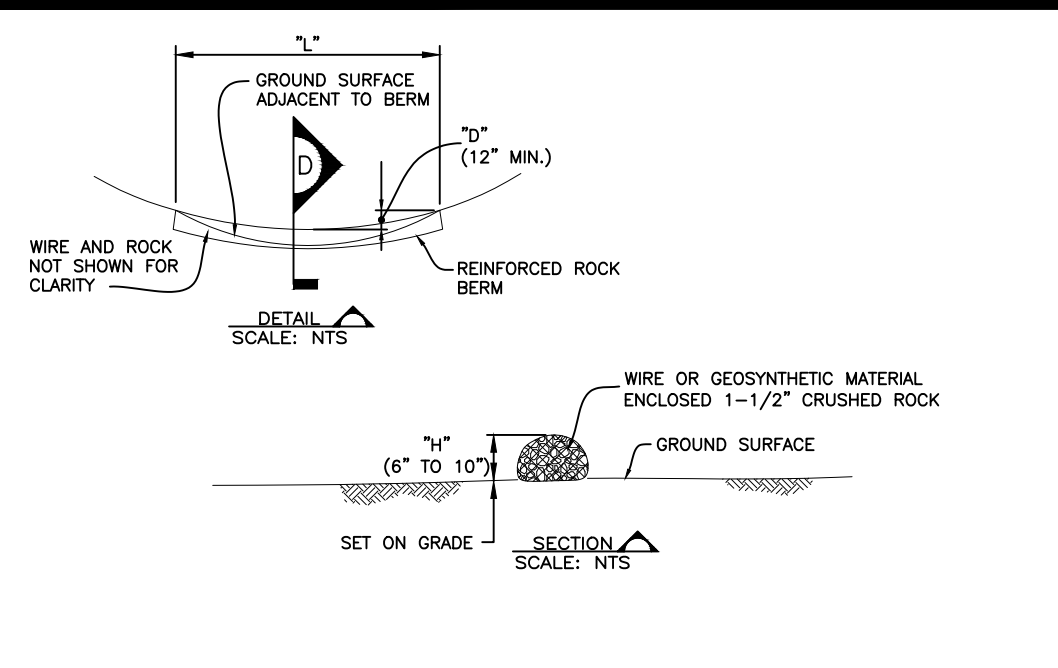

- REINFORCED ROCK BERM INSTALLATION NOTES**
- SEE PLAN VIEW FOR:
 - LOCATIONS OF REINFORCED ROCK BERMS.
 - LENGTH, "L", DEPTH, "D", AND HEIGHT, "H", DIMENSIONS.
 - REINFORCED ROCK BERM SECTION APPLIES TO CULVERT AND INLET PROTECTION.
 - IF LENGTH EXCEEDS LENGTH OF ROCK BERM, TWO OR MORE ROCK BERM SEGMENTS MAY BE REQUIRED AND NEED TO BE LAPPED BY AT LEAST 12" (SIMILAR TO SED LOG)
 - WIRE MESH SHALL BE FABRICATED OF 10 GAUGE WIRE TWISTED INTO A MESH WITH A MAXIMUM OPENING OF 1.0 INCH (COMMONLY TERMED "CHICKEN WIRE").
 - WIRE MESH SHALL BE SECURED USING "HOG RINGS" OR WIRE TIES AT 6-INCH CENTERS ALONG ALL JOINTS AND AT APPROXIMATELY 2-INCH CENTERS ON ENDS OF BERM.
 - FOR CONCENTRATED FLOW AREAS THE ENDS OF THE REINFORCED ROCK BERM SHALL BE 12" HIGHER THAN THE CENTER OF THE BERM.
 - CRUSHED ROCK SHALL BE FRACTURED FACE (ALL SIDES) (1-1/2" MINUS). RECYCLED CONCRETE CANNOT BE USED.
 - REINFORCED ROCK BERM TO PROVIDE STORAGE VOLUME EQUAL TO 1800 CUBIC FEET PER UPSTREAM ACRE.
 - IF LENGTH REQUIRED EXCEEDS THE LENGTH OF THE ROCK BERM, TWO OR MORE ROCK BERM SEGMENTS MAY BE REQUIRED AND SHALL BE OVERLAPPED A MINIMUM OF 12".

- REINFORCED ROCK BERM MAINTENANCE NOTES**
- THE GESC PERMITTEE SHALL INSPECT AS NECESSARY TO ENSURE THE ADEQUACY AND FUNCTIONALITY OF THE CONTROL MEASURE.
 - SEDIMENT ACCUMULATED UPSTREAM OF REINFORCED ROCK BERM SHALL BE REMOVED WHEN THE SEDIMENT DEPTH UPSTREAM OF FILTER IS WITHIN APPROXIMATELY 1/2 OF THE HEIGHT OF THE CREST.
 - REINFORCED ROCK BERMS ARE TO REMAIN IN PLACE UNTIL THE UPSTREAM DISTURBED AREA IS STABILIZED.
 - WHEN REINFORCED ROCK BERMS ARE REMOVED, ANY DISTURBED AREA SHALL BE DRILL SEEDED AND CRMP MULCHED OR OTHERWISE STABILIZED IN A MANNER APPROVED BY THE COUNTY.

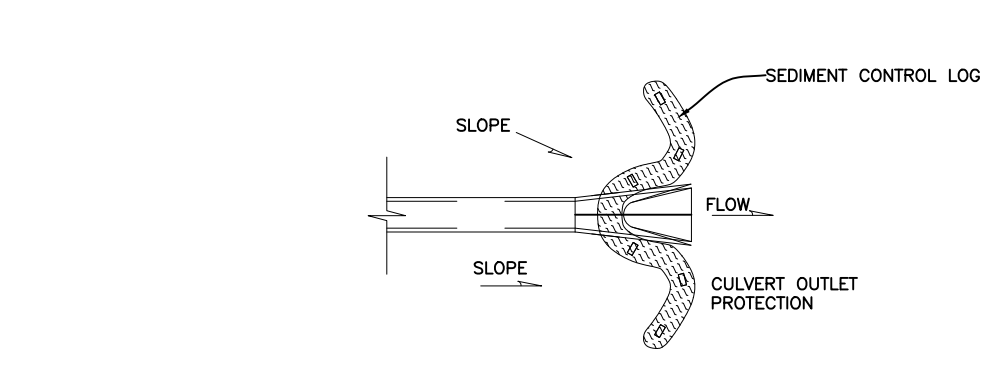
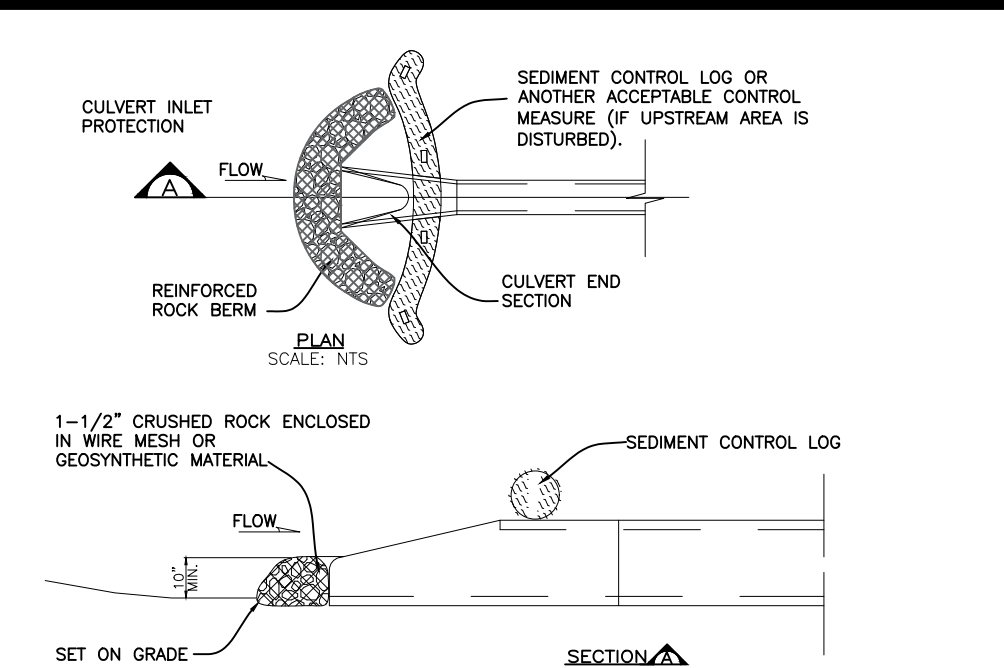

- INSTALLATION NOTES**
- SEE PLAN VIEW FOR:
 - LOCATIONS OF CULVERT PROTECTION.
 - 1-1/2" CRUSHED ROCK SHALL BE FRACTURED FACE ON ALL SIDES.
 - WIRE MESH SHALL BE FABRICATED OF WIRE TWISTED INTO A MESH WITH A MAXIMUM OPENING OF 1.0 INCH (COMMONLY TERMED "CHICKEN WIRE").
 - WIRE MESH SHALL BE SECURED USING "HOG RINGS" OR WIRE TIES AT APPROXIMATELY 6-INCH CENTERS ALONG ALL JOINTS AND AT APPROXIMATELY 2-INCH CENTERS ON ENDS OF BERM.
 - THE ENDS OF THE REINFORCED ROCK BERM SHALL BE HIGHER THAN THE CENTER OF THE BERM AND ALLOW FOR ADEQUATE OVERTOPPING CAPACITY.
 - CRUSHED ROCK SHALL BE FRACTURED FACE (ALL SIDES) (1-1/2" MINUS). RECYCLED CONCRETE CANNOT BE USED.

- MAINTENANCE NOTES**
- SEDIMENT ACCUMULATED UPSTREAM OF CULVERT INLET FILTER SHALL BE REMOVED WHEN THE SEDIMENT DEPTH UPSTREAM OF FILTER IS 1/2 THE HEIGHT OF THE REINFORCED ROCK BERM.
 - RRB FOR CULVERT PROTECTION ARE TO REMAIN IN PLACE UNTIL THE UPSTREAM DISTURBED AREA IS STABILIZED.
 - WHEN CULVERT INLET FILTERS ARE REMOVED, ANY DISTURBED AREA SHALL BE SEEDED OR OTHERWISE STABILIZED IN A MANNER APPROVED BY THE COUNTY.

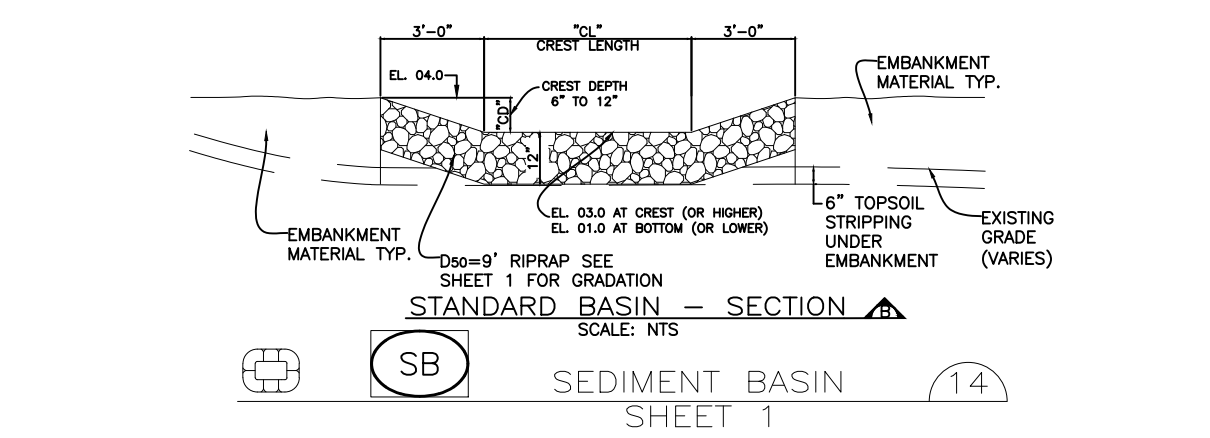
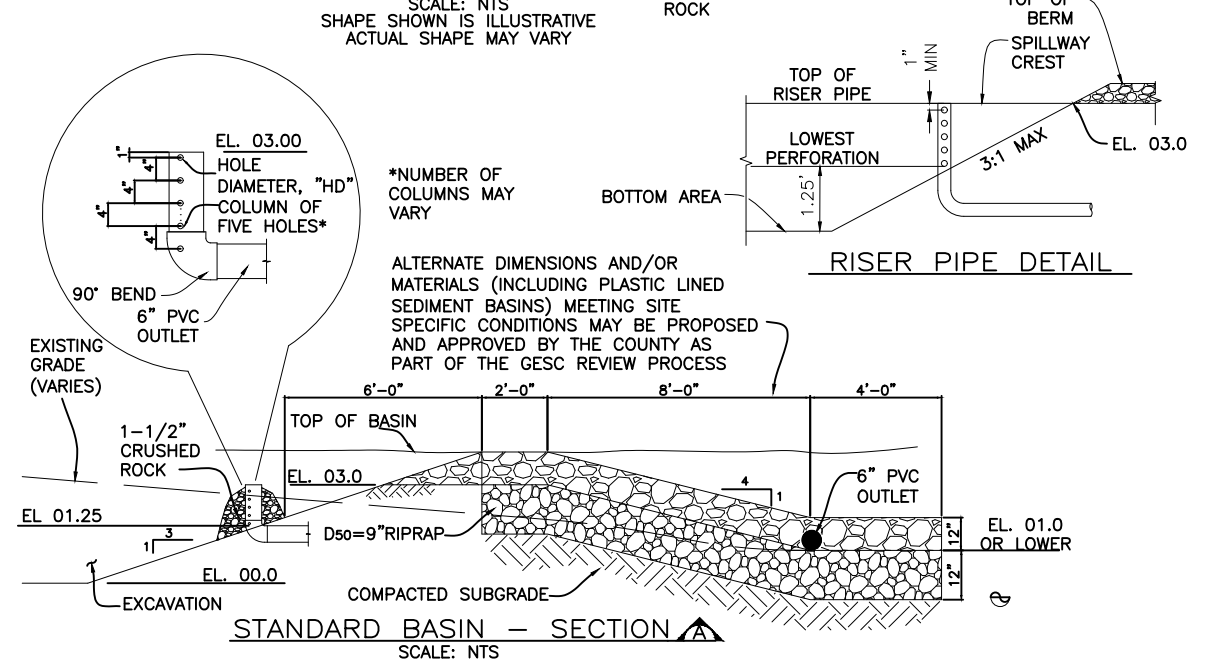
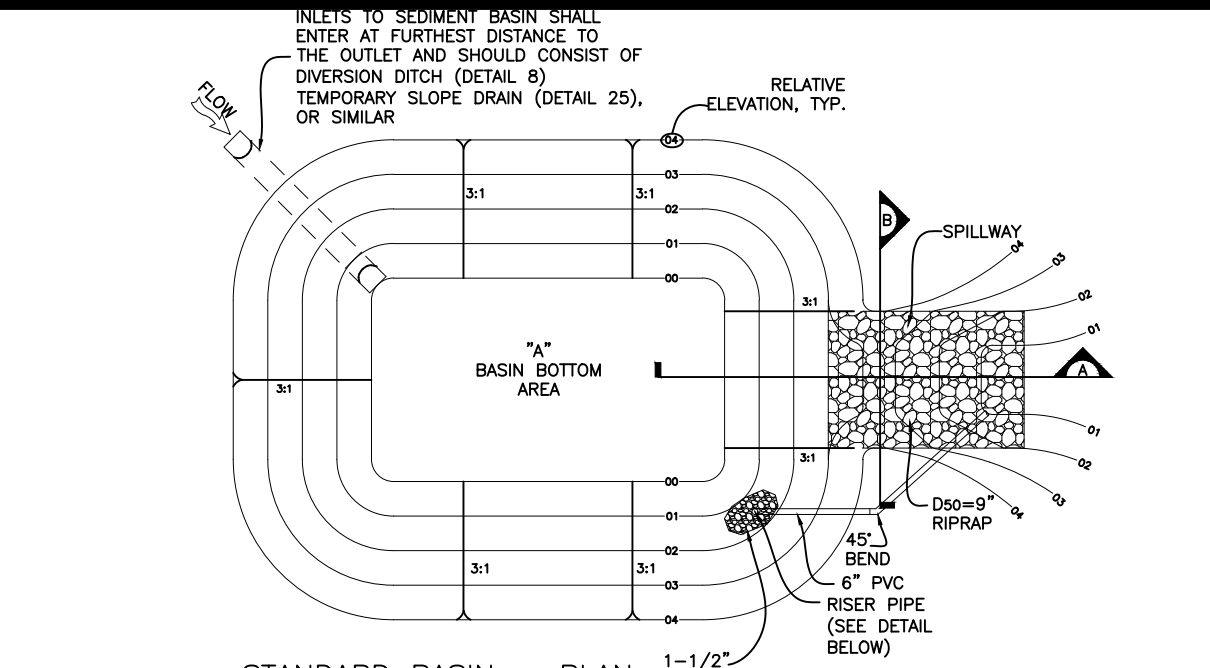

- SEDIMENT BASIN INSTALLATION NOTES**
- MAXIMIZE THE DISTANCE BETWEEN INFLOW POINT AND OUTLET, AS FEASIBLE.
 - SEE PLAN VIEW FOR:
 - LOCATION OF SEDIMENT BASIN.
 - TYPE OF BASIN (STANDARD BASIN OR NON-STANDARD BASIN).
 - FOR STANDARD BASIN, CREST LENGTH, "CL", CREST DEPTH, "CD", BOTTOM AREA, "A", AND HOLE DIAMETER, "HD".
 - FOR NON-STANDARD BASIN, SEE CONSTRUCTION DRAWINGS FOR DESIGN OF BASIN INCLUDING RISER HEIGHT, "R", NUMBER OF COLLARS, "N", HOLE DIAMETER, "HD", AND PIPE DIAMETER "D".
 - SEDIMENT BASINS MUST BE INSTALLED AS INDICATED ON INITIAL GESC PLAN, AS SOON AS FEASIBLE AFTER PERMIT ISSUANCE.
 - PERMITTEE IS RESPONSIBLE FOR ADEQUATE PHASING OF SEDIMENT BASIN IF ALL CONDITIONS CANNOT BE INSTALLED IMMEDIATELY.
 - EMBANKMENT MATERIAL SHALL BE COMPACTED.
 - PIPE SCH 40 OR GREATER SHALL BE USED.
 - CRUSHED ROCK SHALL BE FRACTURED FACE (ALL SIDES) (1-1/2" MINUS). RECYCLED CONCRETE CANNOT BE USED.
 - THE DETAILS SHOWN ON THIS SHEET PERTAIN TO STANDARD SEDIMENT BASIN(S) IDENTIFIED ON THE GESC PLAN VIEW DRAWINGS USED FOR DRAINAGE AREAS LESS THAN 15 ACRES. SEE CONSTRUCTION DRAWINGS FOR EMBANKMENT, STORAGE VOLUME, SPILLWAY, OUTLET, AND OUTLET PROTECTION DETAILS FOR ANY SEDIMENT BASIN(S) THAT HAVE BEEN INDIVIDUALLY DESIGNED FOR DRAINAGE AREAS LARGER THAN 15 ACRES.

- SEDIMENT BASIN MAINTENANCE NOTES**
- THE GESC PERMITTEE SHALL INSPECT AS NECESSARY TO ENSURE THE ADEQUACY AND FUNCTIONALITY OF THE CONTROL MEASURE.
 - SEDIMENT SHALL BE REMOVED FROM THE SEDIMENT BASIN WHEN DESIGNED STORAGE VOLUME IS NO MORE THAN ONE-THIRD FILLED WITH SEDIMENT, OR AS OTHERWISE SPECIFIED BY THE COUNTY.
 - SEDIMENT BASINS ARE TO REMAIN IN PLACE AND KEPT IN MAINTAINED CONDITION UNTIL THE UPSTREAM DISTURBED AREA IS STABILIZED.
 - THE DISTURBED AREA SHALL BE SEEDED AND MULCHED OR OTHERWISE STABILIZED IN A MANNER APPROVED BY THE COUNTY.
 - TRASH AND DEBRIS SHALL BE REMOVED FROM THE SEDIMENT BASIN AS NEEDED TO PREVENT CLOGGING AT THE OUTLET.

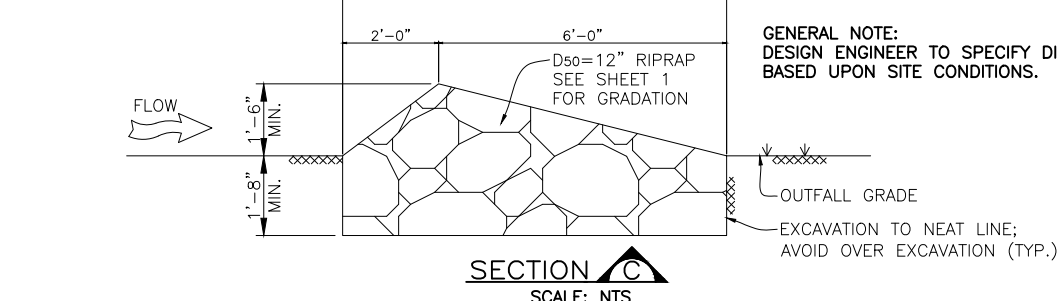
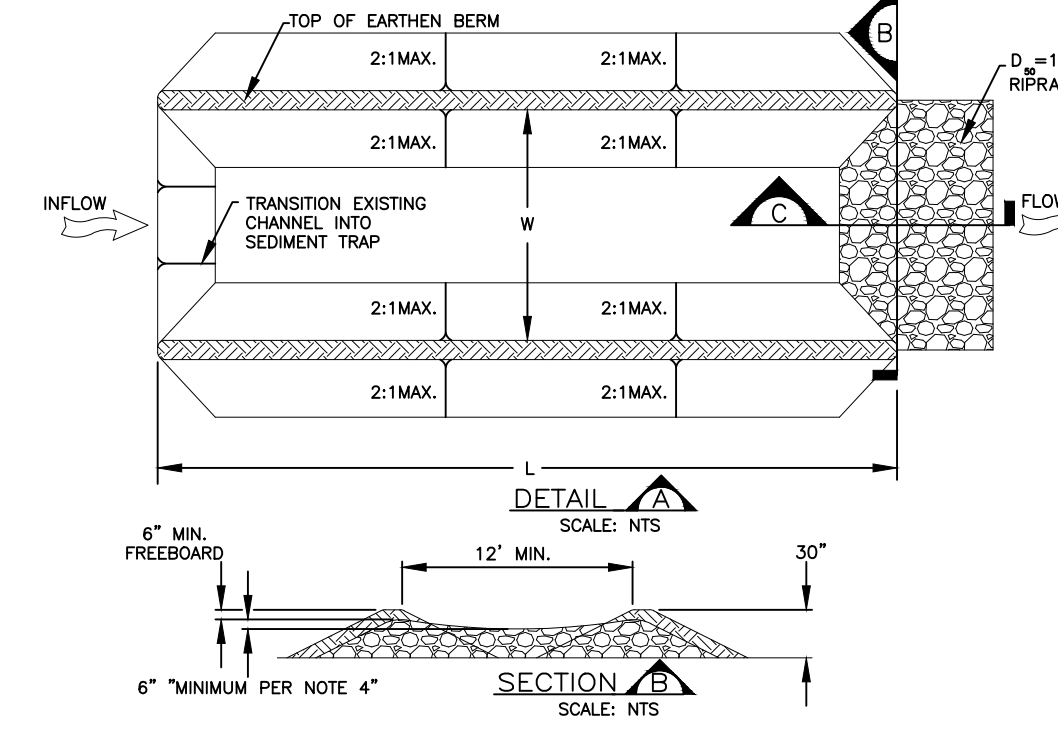

- SEDIMENT TRAP INSTALLATION NOTES**
- SEE PLAN VIEW FOR:
 - LOCATION, LENGTH AND WIDTH OF SEDIMENT TRAP.
 - SEDIMENT TRAPS INDICATED ON INITIAL GESC PLAN SHALL BE INSTALLED PRIOR TO ANY OTHER LAND-DISTURBING ACTIVITIES OR AS SOON AS FEASIBLE.
 - SEDIMENT TRAP BERM SHALL BE CONSTRUCTED FROM MATERIAL FROM EXCAVATION. THE BERM SHALL BE COMPACTED.
 - RIPRAP OUTLET SHALL BE CONSTRUCTED WITH D₅₀ = 12" RIPRAP WITH A MINIMUM OVERTOP OF 6".
 - THE TOP OF THE EARTHEN BERM SHALL ALLOW FOR OVERTOPPING.
 - THE ENDS OF THE RIPRAP OUTLET STRUCTURE SHALL ALLOW FOR OVERTOPPING.
 - OVERTOPPING MUST OCCUR ON A STABILIZED SURFACE TO INCLUDE WELL VEGETATED AREAS, RIP RAP, OR PAVEMENT.
 - SEDIMENT TRAP SIZED TO PROVIDE STORAGE VOLUME EQUAL TO 1800 CUBIC FEET PER UPSTREAM ACRE.

- SEDIMENT TRAP MAINTENANCE NOTES**
- THE GESC PERMITTEE SHALL INSPECT AS NECESSARY TO ENSURE THE ADEQUACY AND FUNCTIONALITY OF THE CONTROL MEASURE.
 - SEDIMENT ACCUMULATED UPSTREAM OF RIPRAP SHALL BE REMOVED WHEN THE UPSTREAM SEDIMENT DEPTH IS WITHIN 1/2 THE HEIGHT OF THE RIPRAP OUTLET STRUCTURE.
 - SEDIMENT TRAPS SHALL REMAIN IN PLACE UNTIL THE UPSTREAM DISTURBED AREA IS STABILIZED.
 - WHEN SEDIMENT TRAPS ARE REMOVED THE DISTURBED AREA SHALL BE DRILL SEEDED AND CRMP MULCHED OR STABILIZED IN A MANNER APPROVED BY THE COUNTY.



- SEEDING AND MULCHING INSTALLATION NOTES**
- SEE PLAN VIEW FOR:
 - AREA OF SEEDING AND MULCHING.
 - TYPE OF SEED MIX.
 - ALL BRANDS FURNISHED SHALL BE FREE FROM SUCH NOXIOUS WEED SEEDS TO INCLUDE BUT NOT LIMITED TO RUSSIAN OR CANADIAN THISTLE, COARSE FESCUE, EUROPEAN BIRCHWOOD, JOHNSON GRASS, KNAF WEED, LEAFY SPURGE AND FREE FROM COLORADO LIST A, B, & C WEEDS.
 - SEED WHICH HAS BECOME WET, MOLDY, OR OTHERWISE DAMAGED IN TRANSIT OR IN STORAGE WILL NOT BE ACCEPTABLE. SEED TICKETS SHALL BE PROVIDED TO THE COUNTY UPON REQUEST.
 - DRILL SEEDING MIX SHALL CONFORM TO THE TABLE BELOW UNLESS OTHERWISE APPROVED BY THE COUNTY. IF THE SEED AVAILABLE ON THE MARKET DOES NOT MEET THE MINIMUM PURITY AND GERMINATION PERCENTAGES SPECIFIED, THE CONTRACTOR MUST COMPENSATE FOR A LESSER PERCENTAGE OF PURITY OR GERMINATION BY FURNISHING SUFFICIENT ADDITIONAL SEED TO EQUAL THE SPECIFIED PRODUCT. THE TAGS FROM THE SEED MIXES MUST BE SUPPLIED TO CONTRACTOR AND FORWARDED TO THE COUNTY GESC INSPECTOR.
 - THE FORMULA USED FOR DETERMINING THE QUANTITY OF PURE LIVE SEED (PLS) SHALL BE (POUNDS OF SEED) X (PURITY) X (GERMINATION) = POUNDS OF PURE LIVE SEED (PLS).
 - PERMANENT SEED MIX SHALL BE USED UNLESS OTHERWISE APPROVED BY THE COUNTY.
 - ALL AREAS TO BE SEEDED AND MULCHED SHALL HAVE NATIVE TOPSOIL OR APPROVED SOIL AMENDMENTS SPREAD TO A DEPTH OF AT LEAST 6 INCHES (LOOSE DEPTH). ALL DISTURBED AREAS SHALL BE FILLED TO A DEPTH OF 6 INCHES PRIOR TO SPREADING TOPSOIL. THE TOP 6 INCHES OF THE SEED BED SHALL BE GENERALLY FREE OF ROCKS GREATER THAN 4 INCHES AND SOIL CLOSURE GREATER THAN 2 INCHES AND WOODY DEBRIS. SEEDING OVER ANY COMPACTED AREAS THAT HAVEN'T BEEN THOROUGHLY TILLED SHALL BE REJECTED.
 - SEED IS TO BE APPLIED USING A MECHANICAL DRILL TO A DEPTH OF 1/4 INCH AND NOT MORE THAN 3/4 INCH. ROW SPACING SHALL BE NO MORE THAN 6 INCHES.
 - NEED FREE AND SEED FREE LONG STEMMED STRAW MULCH SHALL BE APPLIED AT A RATE OF 4,000 POUNDS PER ACRE AND MECHANICALLY CRIMPED INTO THE SOIL. MULCH SHALL BE APPLIED AND MECHANICALLY ANCHORED TO A DEPTH OF AT LEAST 3 INCHES.
 - IF THE PERMITTEE DEMONSTRATES TO THE COUNTY THAT IT IS NOT POSSIBLE TO DRILL SEED, SEED IS TO BE UNIFORMLY BROADCAST AT TWO TIMES THE DRILLED RATE, THEN LIGHTLY RAKED TO PROVIDE A SEED DEPTH OF APPROXIMATELY 1/4 INCH, THEN ROLLED TO CONTACT, THEN MULCHED AS SPECIFIED ABOVE.
 - MULCH SHALL BE APPLIED WITHIN 24-HOURS OF SEEDING.
 - TACKIFIER SHOULD BE UTILIZED TO REDUCE STRAW DISPLACEMENT.

TEMPORARY DRILL SEEDING MIX

SPECIES	VARIETY	NOTES	% IN MIX	POUNDS OF PLS PER ACRE
SMOOTH BROMEGRASS	LINCOLN	PICS	30	3.9
INTERMEDIATE WHEATGRASS	OHIE	PICS	30	4.5
PUBESCENT WHEATGRASS	LUNA	PICS	30	4.2
ANNUAL RYEGRASS	N/A	AICB	10	0.8
TOTAL			100	13.4

NOTES: P=PERENNIAL
A=ANNUAL
H=INTRODUCED
C=COOL SEASON
S=SOO TOLERANT
B=BUNCHGRASS

- SEEDING AND MULCHING MAINTENANCE NOTES**
- SEEDED AND MULCHED AREAS SHALL BE INSPECTED FOR REQUIRED COVERAGE UNTIL FINAL CLOSE OUT IS ISSUED. REPAIRS AND RE-SEEDING AND MULCHING SHALL BE UNDERTAKEN AFTER THE FIRST GROWING SEASON FOR ANY AREAS FAILING TO MEET THE REQUIRED COVERAGE.
 - RILL AND GULLY EROSION SHALL BE FILLED WITH TOPSOIL PRIOR TO RESEEDING. THE RESEEDING METHOD SHALL BE APPROVED BY THE COUNTY.



UPLAND SEED MIX - WITH FORBS¹

SPECIES	SCIENTIFIC NAME	SEASON	% IN MIX	SEEDS/LB.	LBS PLS ² /AC
NATIVE GRASSES					
BIG BLUESTEM	ANDROPOGON GERARDII	WARM	8	130,000	1.6
SIDEOTS GRAMA	BOUTELOUA CURTIPENDULA	WARM	8	191,000	1.1
BLUE GRAMA	BOUTELOUA GRACILIS	WARM	8	825,000	0.3
CANADA WILDRYE	ELYMUS CANADENSIS	COOL	8	115,000	1.8
THICKSPIKE WHEATGRASS	ELYMUS LANCOLATUS SPP. LANCEOLATUS	COOL	5	154,000	0.8
STREAMBANK WHEATGRASS	ELYMUS LANCOLATUS SPP. PSAMMOPHILUS	COOL	5	156,000	0.8
SLENDER WHEAT GRASS	ELYMUS TRACHYCALLUS	WARM	10	159,000	1.6
NEEDLE AND THREAD GRASS	HESPEROSTIPA COMATA	COOL	8	115,000	1.8
WESTERN WHEATGRASS	PASCOPYRUM SMITHI	COOL	10	110,000	2.4
INDIAN GRASS	SORGHASTRUM NUTANS	WARM	10	170,000	1.5
SAND DROPSSEED	SPOROBOLUS CRYPTANDRUS	WARM	10	5,298,000	0.1
NATIVE WILDFLOWERS					
BLACK-BEED SUSAN	RUBICEKIA HIRTA	SUMMER-FALL	1	1,710,000	0.1
SULFUR FLOWER	ERODIUM UMBELLIFORME	FALL	2	209,000	0.3
PRAIRIE ASTER	MACRODORIS TRINACITOIDA	SUMMER	1	408,000	0.1
PURPLE PRAIRIE CLOVER	DALEA PURPUREUM	SUMMER	1	210,000	0.1
WESTERN YARROW	ACHILLEA MILEFOLIUM VAR. OCCIDENTALIS	SUMMER-FALL	2	2,770,000	0.1
PLAINS COREOPSIS	COREOPSIS TINCTORIA	SUMMER-FALL	1	1,400,000	0.1
INDIAN BLANKET FLOWER	GALLIARDA ARISTATA	SUMMER-FALL	1	132,000	0.2
PURPLE CONFLOWER	ECHINACEA PURPUREA	SUMMER	1	117,000	0.2
TOTAL			100	15 LBS PLS ² /AC	

PERMANENT DRILL SEEDING - WETLAND SEED MIX¹

SPECIES	SCIENTIFIC NAME	SEASON	% IN MIX	SEEDS/LB.	LBS PLS ² /AC
NATIVE WILDFLOWERS					
SLOUGH GRASS	BECKMANNIA SYZYGACHE	COOL	20	1,150,000	0.5
CANADIAN REED GRASS	CALAMAGROSTIS CANADENSIS	COOL	20	2,270,000	0.2
TUFTED HAIR GRASS	DESCHAMPSIA CESPIITOSA	COOL	10	2,500,000	0.1
COMMON SPIKE RUSH	ELEOCHARIS PALUSTRIS	COOL	15	620,000	0.6
BAL TIC RUSH	JUNCUS BALTICUS	COOL	15	10,900,000	0.4
KNOTTED RUSH	JUNCUS NODOSUS	COOL	10	12,300,000	0.1
TORREY'S RUSH	JUNCUS TORREYI	COOL	10	12,300,000	0.1
TOTAL			100	2 LBS PLS ² /AC	

PERMANENT DRILL SEEDING^{1,2} - TRANSITION SEED MIX - WITHOUT FORBS

SPECIES	SCIENTIFIC NAME	SEASON	% IN MIX	SEEDS/LB.	LBS PLS ² /AC
NATIVE GRASSES					
CANADA WILDRYE	ELYMUS CANADENSIS	COOL	15	115,000	3.4
STREAMBANK WHEATGRASS	ELYMUS LANCOLATUS SPP. PSAMMOPHILUS	COOL	15	156,000	2.5
SLENDER WHEAT GRASS	ELYMUS TRACHYCALLUS	WARM	10	159,000	1.6
BAL TIC RUSH	JUNCUS BALTICUS	COOL	15	10,900,000	0.1
SWITCHGRASS	PANICUM VIRGATUM	WARM	15	389,000	1.0
WESTERN WHEATGRASS	PASCOPYRUM SMITHI	COOL	15	110,000	3.6
SAND DROPSSEED	SPOROBOLUS AIROIDES	WARM	15	1,758,000	0.2
TOTAL			100	12.4 LBS PLS ² /AC	

PERMANENT DRILL SEEDING^{1,2} - TRANSITION SEED MIX - WITH FORBS

SPECIES	SCIENTIFIC NAME	SEASON	% IN MIX	SEEDS/LB.	LBS PLS ² /AC
NATIVE GRASSES					
CANADA WILDRYE	ELYMUS CANADENSIS	COOL	15	115,000	3.4
STREAMBANK WHEATGRASS	ELYMUS LANCOLATUS SPP. PSAMMOPHILUS	COOL	15	156,000	2.5
SLENDER WHEAT GRASS	ELYMUS TRACHYCALLUS	WARM	10	159,000	1.6
BAL TIC RUSH	JUNCUS BALTICUS	COOL	15	10,900,000	0.1
SWITCHGRASS	PANICUM VIRGATUM	WARM	15	389,000	1.0
WESTERN WHEATGRASS	PASCOPYRUM SMITHI	COOL	15	110,000	3.6
SAND DROPSSEED	SPOROBOLUS AIROIDES	WARM	15	1,758,000	0.2
TOTAL			100	15.5 LBS PLS ² /AC	



UTILITY NOTIFICATION CENTER OF COLORADO
CALL BEFORE YOU DIG
811
Call 2 days prior to any digging, grading or excavating for the marking of underground member utilities

ARAPAHOE COUNTY
PUBLIC WORKS AND DEVELOPMENT
6924 S. LIMA STREET
CENTENNIAL, CO 80112
720-874-6500



GRADING EROSION AND SEDIMENT CONTROL
STANDARD NOTES AND DETAILS
REVISED OCTOBER 2025
GESC SHEET 3 OF 4

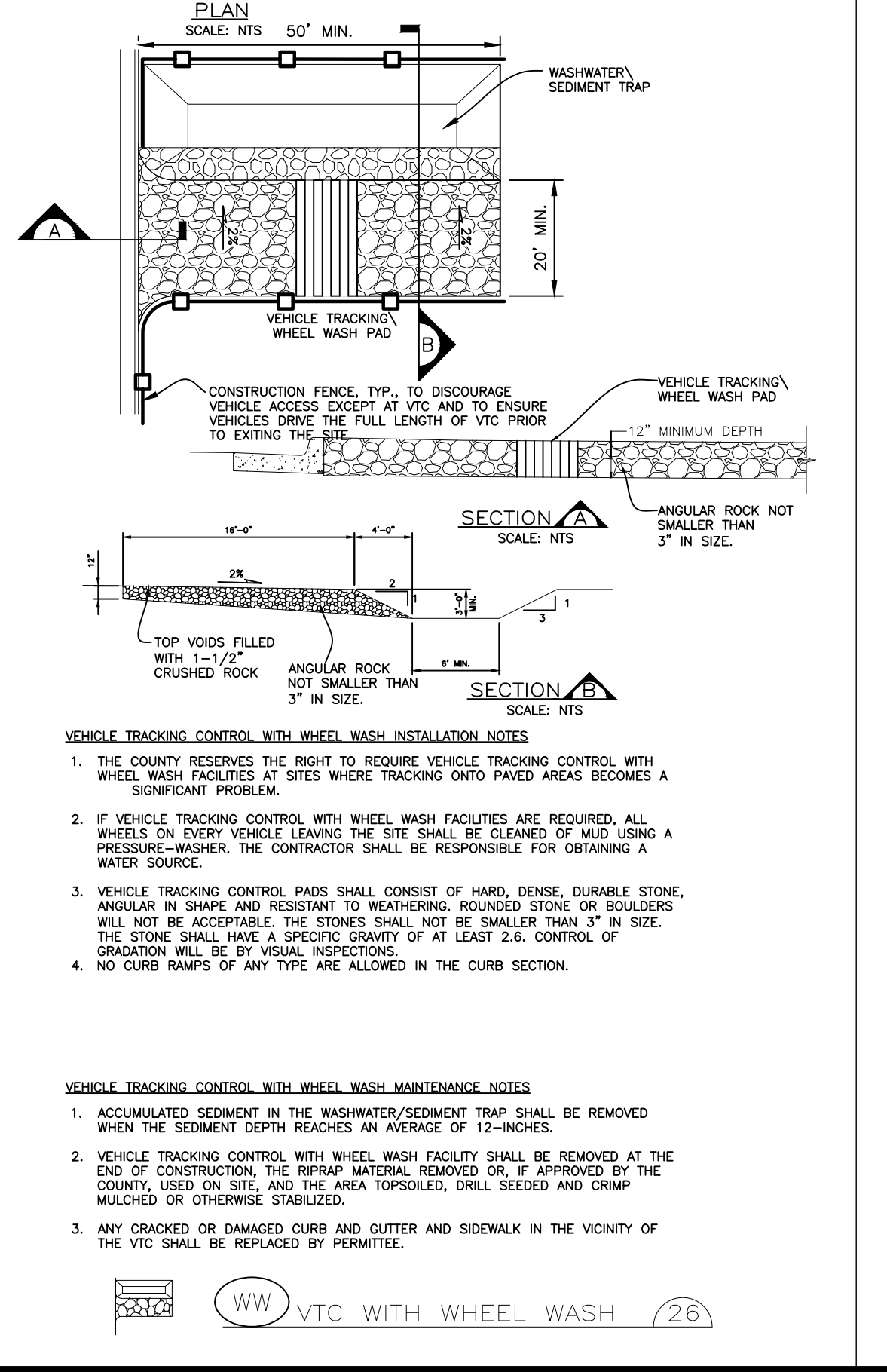
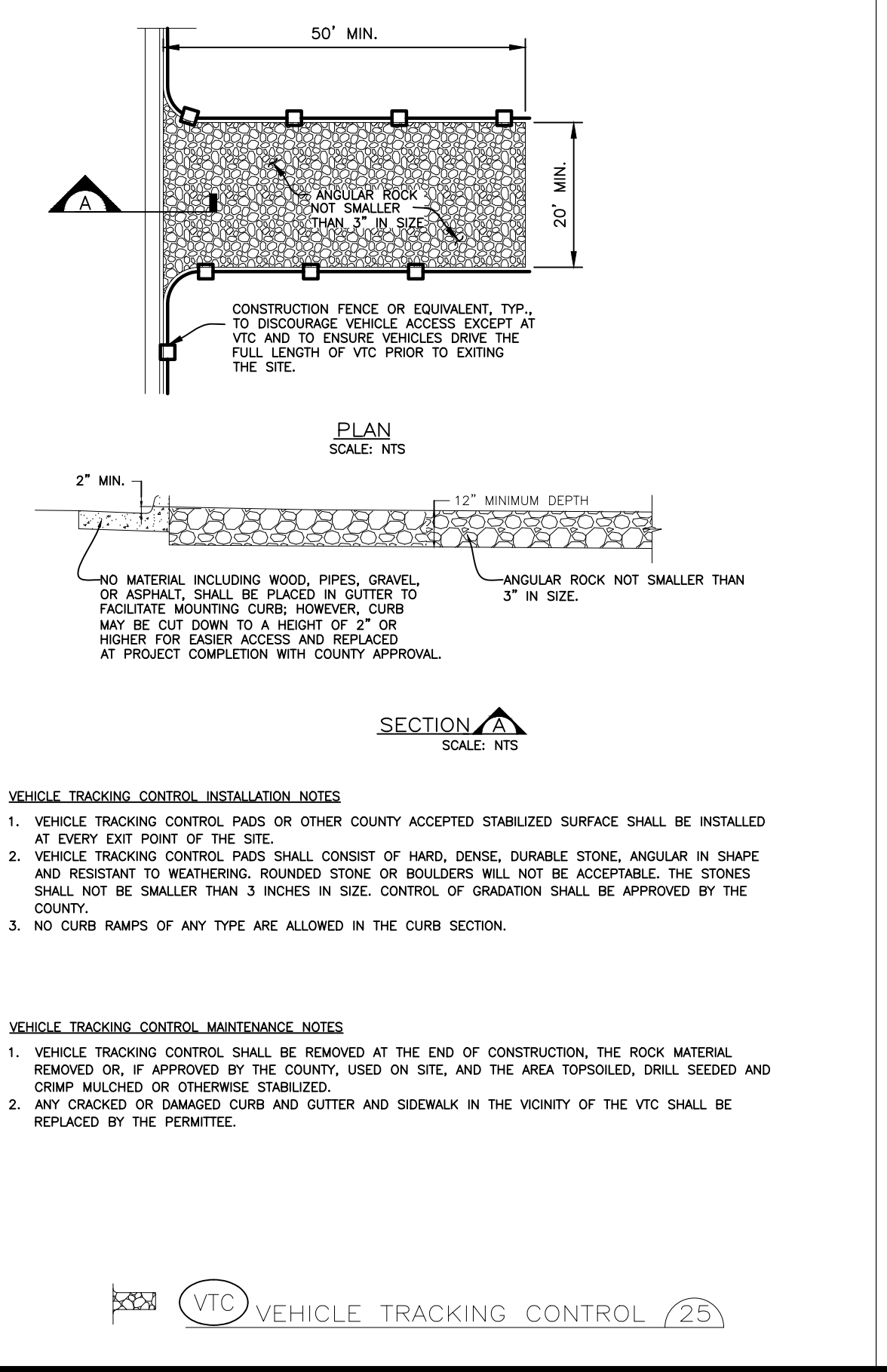
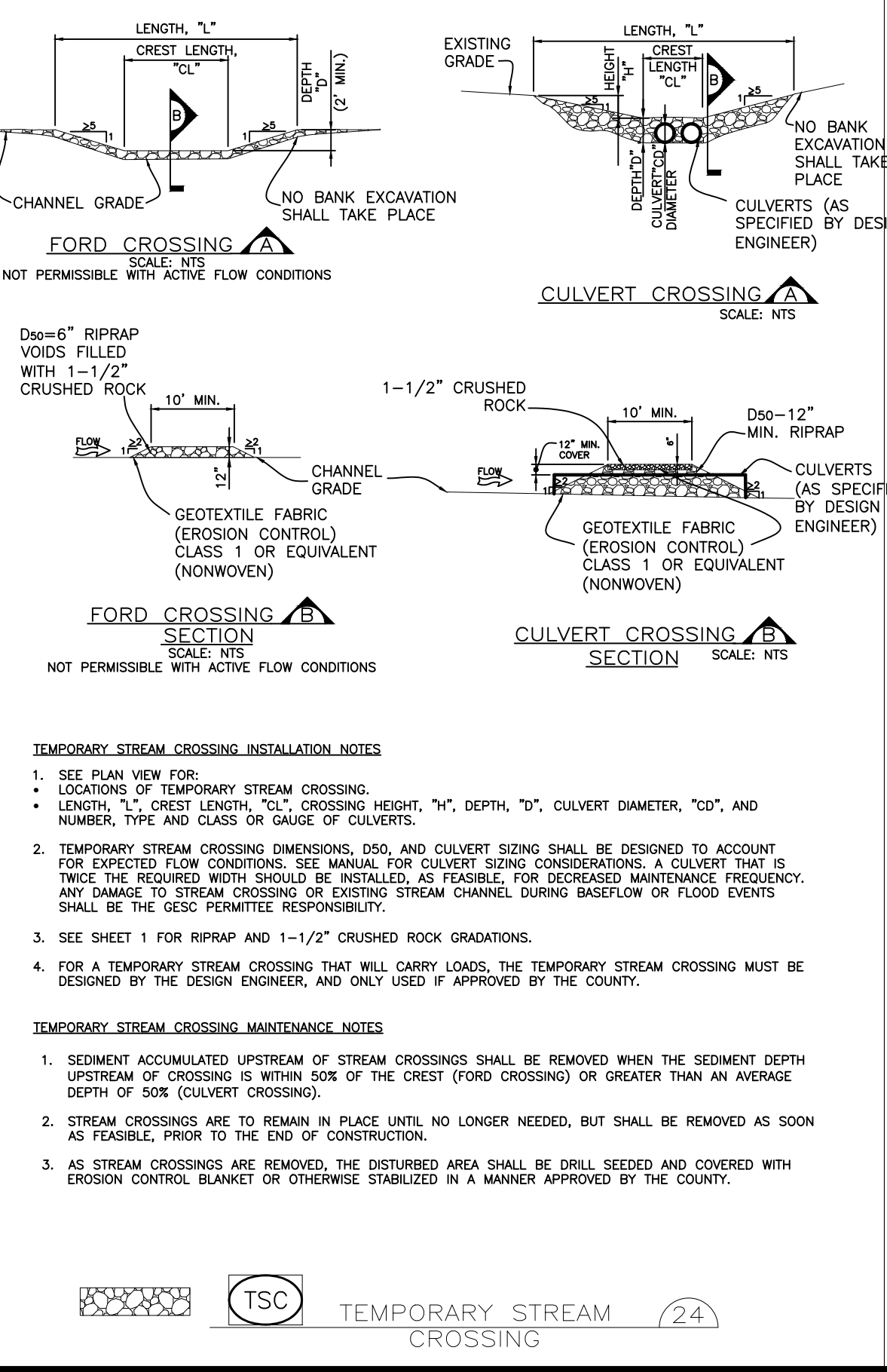
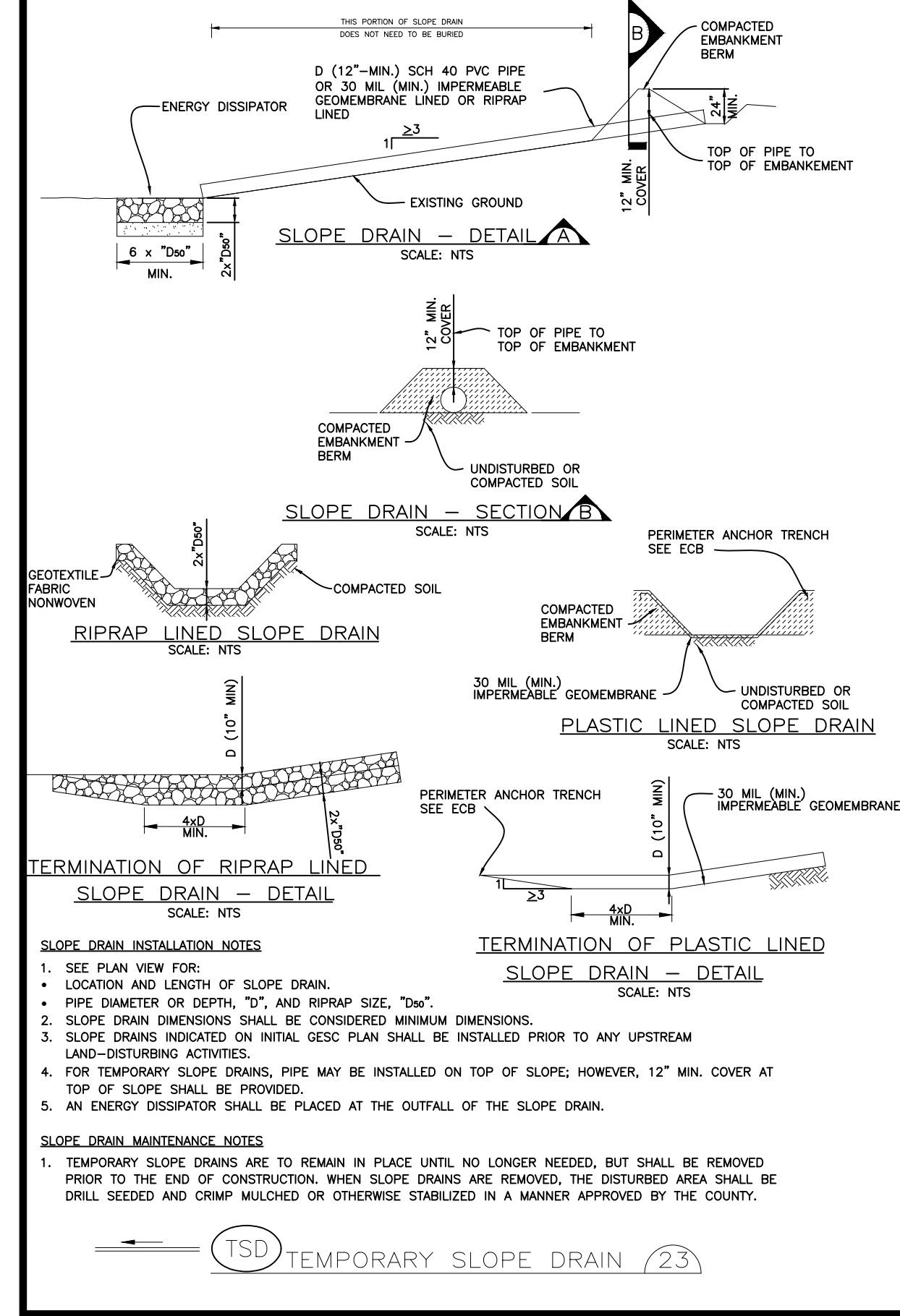
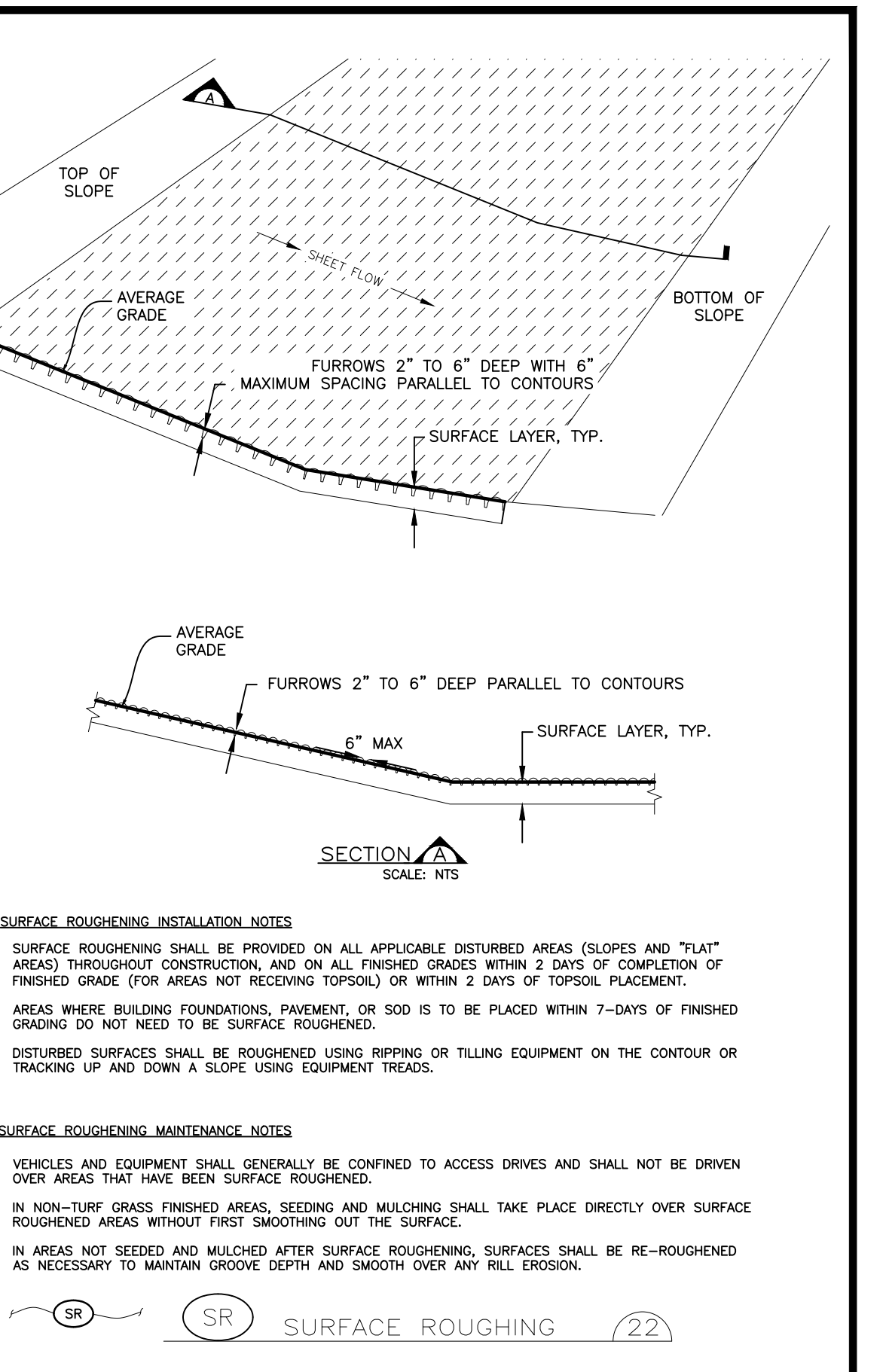
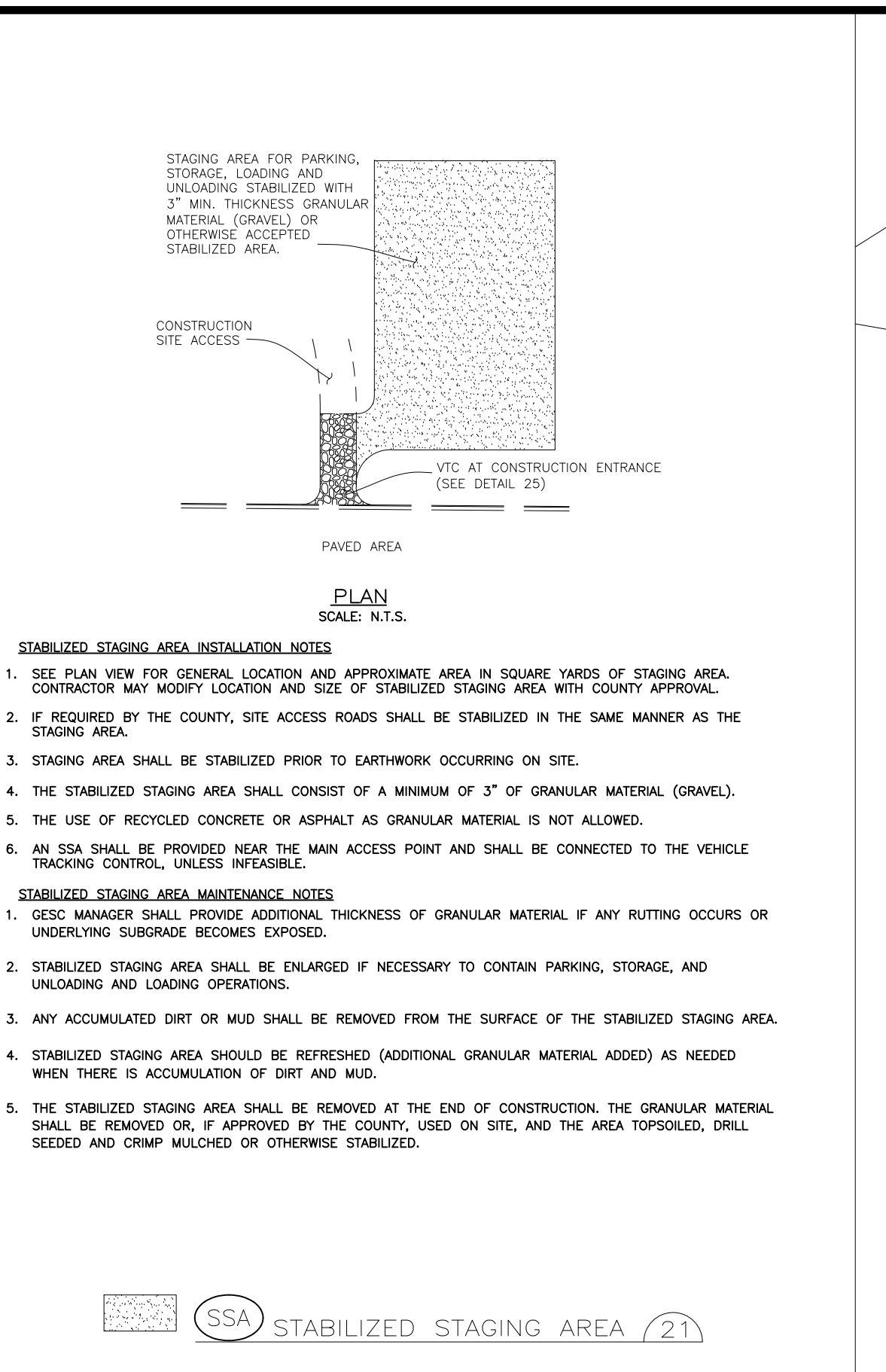
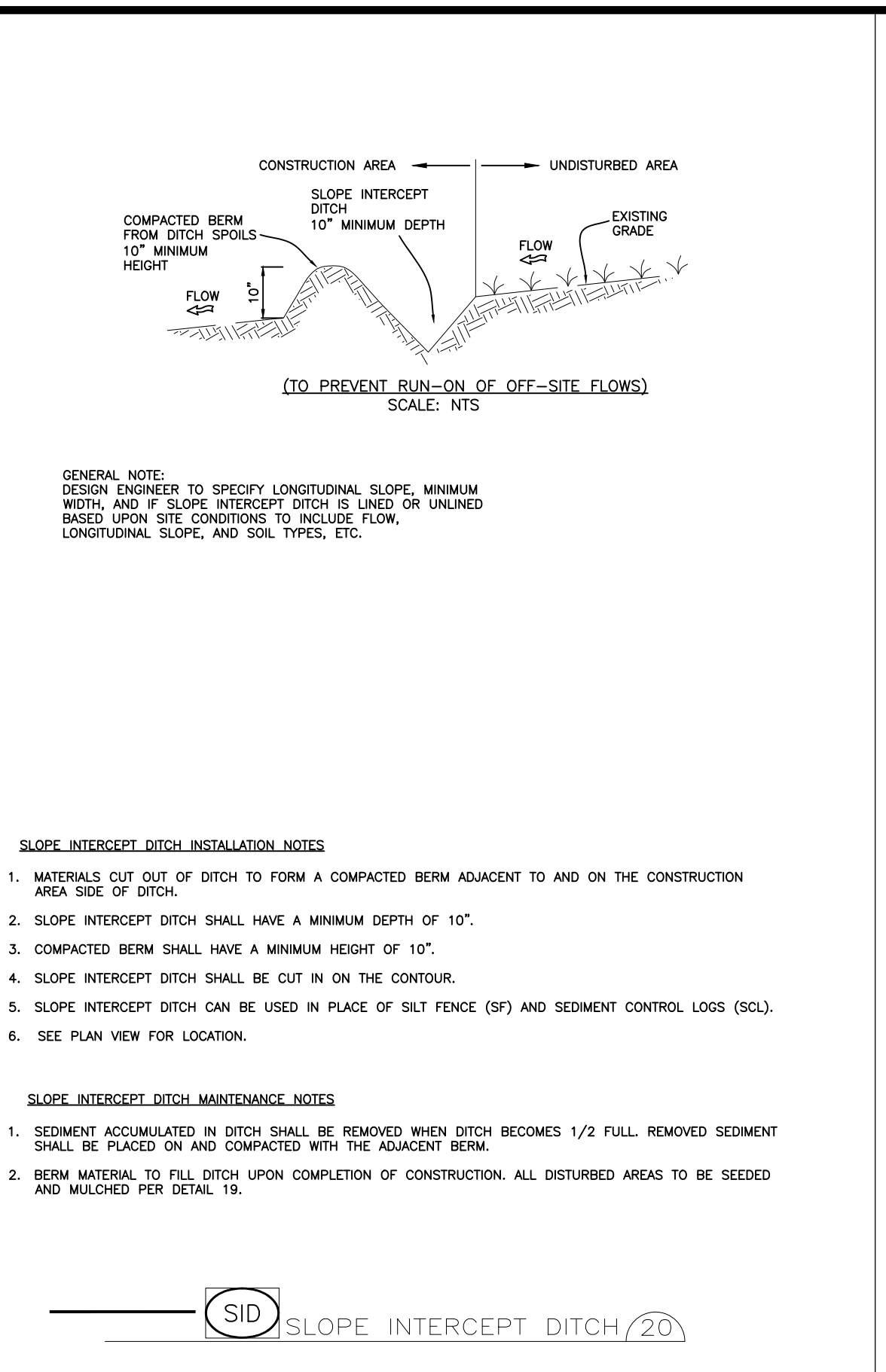
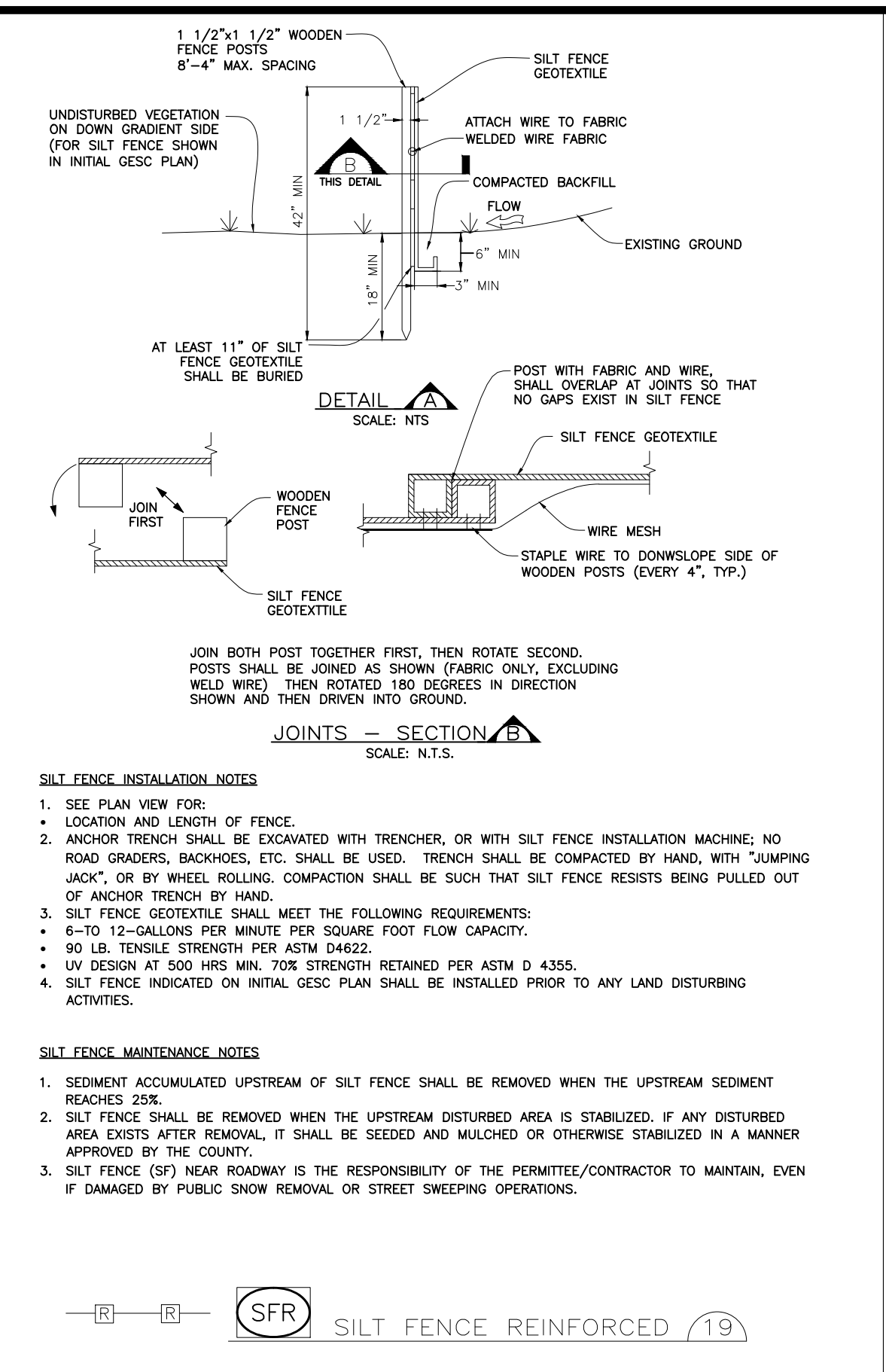
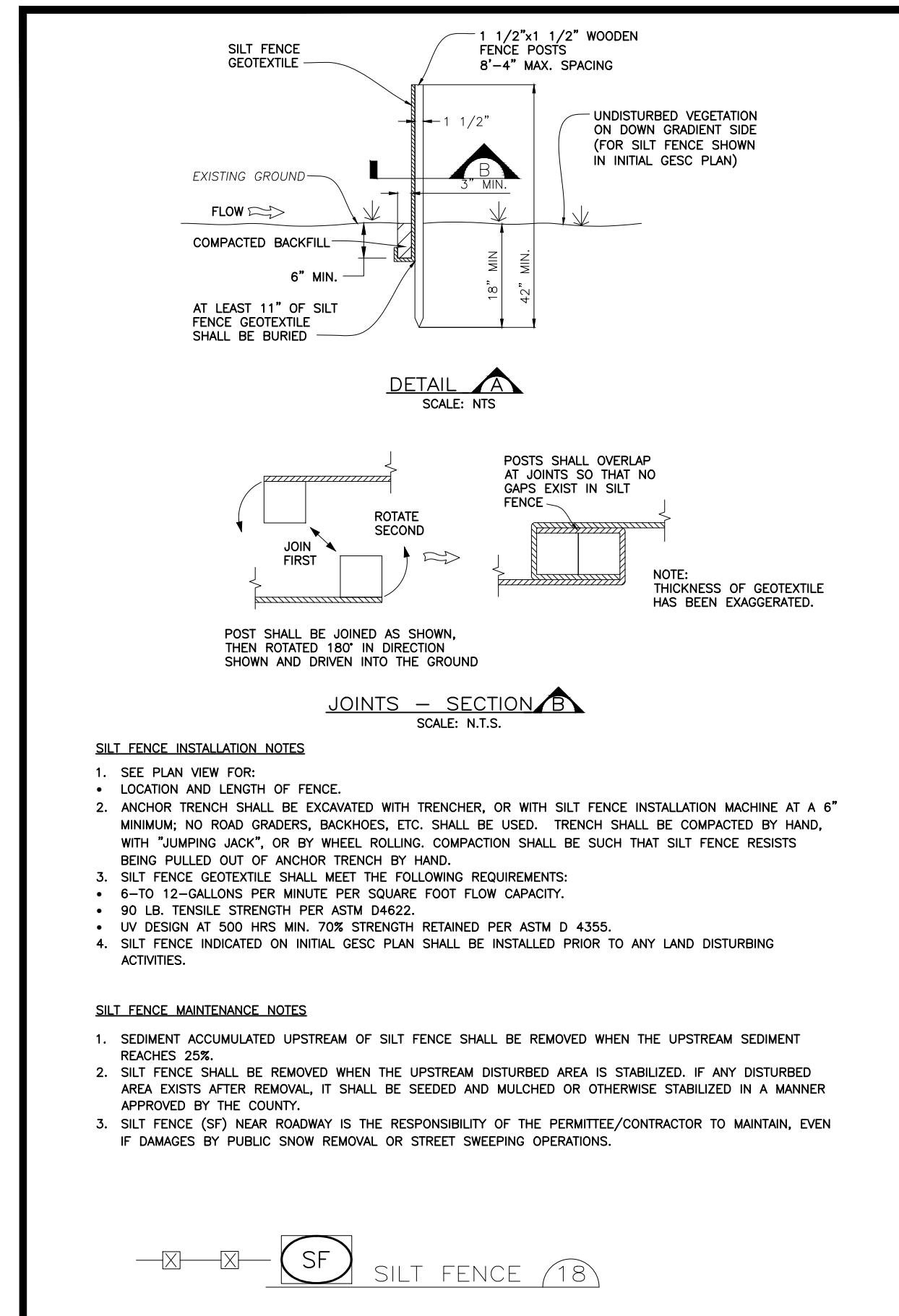

UTILITY NOTIFICATION CENTER OF COLORADO
 CALL BEFORE YOU DIG
811
 Call 2 days prior to any digging, grading or excavating for the marking of underground member utilities

ARAPAHOE COUNTY
 PUBLIC WORKS AND DEVELOPMENT
 6924 S. LIMA STREET
 CENTENNIAL, CO 80112
 720-874-6500



GRADING EROSION AND SEDIMENT CONTROL
 STANDARD NOTES AND DETAILS
 REVISED OCTOBER 2025

GESC SHEET
 4 OF 4

Appendix G–Engineer’s Cost Estimate

GESC Permit

Engineer's Cost Estimate Spreadsheet for Initial and Interim Control Measures

Note: *Initial* and *Interim* Control Measures shall be added together for the Cost Estimate

Project Name:

Date:

No.	Control Measures	ID	Unit	Installation Unit Cost	Initial/Interim Quantity	Initial/Interim Cost
1	Check Dam	CD	LF	\$ 180.00		\$ -
2	Concrete Washout Area	CWA	EA	\$ 1,900.00		\$ -
3	Construction Fence	CF	LF	\$ 3.00		\$ -
4	Construction Markers	CM	LF	\$ 1.00		\$ -
5	Dewatering	DW	EA	\$ 12,000.00		\$ -
6	Diversion Ditch	DD	LF	\$ 27.00		\$ -
7	Erosion Control Blanket	ECB	SY	\$ 8.20		\$ -
8	Inlet Protection	IP	EA	\$ 370.00		\$ -
9	Reinforced Check Dam	RCD	LF	\$ 100.00		\$ -
10	Reinforced Rock Berm	RRB	LF	\$ 44.00		\$ -
11	RRB for Culvert Protection	RRC	LF	\$ 110.00		\$ -
12	Sediment Basin (based on disturbed area tributary to basin)	SB	AC	\$ 2,000.00		\$ -
13	Sediment Control Log	SCL	LF	\$ 5.30		\$ -
14	Sediment Trap (based on disturbed area tributary to trap)	ST	EA	\$ 1,200.00		\$ -

15	Seeding & Mulching	SM	AC	\$ 6,800.00		\$ -
16	Silt Fence	SF	LF	\$ 3.00		\$ -
17	Reinforced Silt Fence	RSF	LF	\$ 4.00		\$ -
18	Stabilized Staging Area	SSA	SY	\$ 13.50		\$ -
19	Surface Roughening	SR	AC	\$ 1,000.00		\$ -
20	Temporary Stream Crossing	TSC	EA	\$ 7,800.00		\$ -
21	Vehicle Tracking Control	VTC	EA	\$ 3,800.00		\$ -
Subtotal of GESC Measures						\$ -
23	Mobilization (10% of subtotal of GESC measures)	MB	LS	10%		\$ -
25	SCM Maintenance (10% of subtotal of GESC measures)	SM	LM	10%		\$ -

Cost of Initial and Interim Control Measures \$ -

10% Collateral Management \$ -

TOTAL COST OF INITIAL AND INTERIM CONTROL MEASURES \$ -

GESC Permit**Engineer's Cost Estimate Spreadsheet for Final Control Measures**

Project Name:

Date:

No.	Control Measures	ID	Unit	Installation Unit Cost	Final Quantity	Final Cost
1	Check Dam	CD	LF	\$ 180.00		\$ -
2	Concrete Washout Area	CWA	EA	\$ 1,900.00		\$ -
3	Construction Fence	CF	LF	\$ 3.00		\$ -
4	Construction Markers	CM	LF	\$ 1.00		\$ -
5	Dewatering	DW	EA	\$ 12,000.00		\$ -
6	Diversion Ditch	DD	LF	\$ 27.00		\$ -
7	Erosion Control Blanket	ECB	SY	\$ 8.20		\$ -
8	Inlet Protection	IP	EA	\$ 370.00		\$ -
9	Reinforced Check Dam	RCD	LF	\$ 100.00		\$ -
10	Reinforced Rock Berm	RRB	LF	\$ 44.00		\$ -
11	RRB for Culvert Protection	RRC	LF	\$ 110.00		\$ -
12	Sediment Basin (based on disturbed area tributary to basin)	SB	AC	\$ 2,000.00		\$ -
13	Sediment Control Log	SCL	LF	\$ 5.30		\$ -
14	Sediment Trap (based on disturbed area tributary to trap)	ST	EA	\$ 1,200.00		\$ -
15	Seeding & Mulching	SM	AC	\$ 6,800.00		\$ -
16	Silt Fence	SF	LF	\$ 3.00		\$ -
17	Reinforced Silt Fence	RSF	LF	\$ 4.00		\$ -
18	Stabilized Staging Area	SSA	SY	\$ 13.50		\$ -
19	Surface Roughening	SR	AC	\$ 1,000.00		\$ -
20	Temporary Stream Crossing	TSC	EA	\$ 7,800.00		\$ -
21	Vehicle Tracking Control	VTC	EA	\$ 3,800.00		\$ -

Subtotal of GESC Measures						\$	-
23	Mobilization (10% of subtotal of GESC measures)	MB	LS	10%		\$	-
25	SCM Maintenance (10% of subtotal of GESC measures)	SM	LM	10%		\$	-

Cost of Final Control Measures \$ -

10% Collateral Management \$ -

TOTAL COST OF INITIAL AND INTERIM CONTROL MEASURES \$ -

**ESC Permit
Engineer's Cost Estimate Spreadsheet**

Project Name:

Date:

No.	Control Measures	ID	Unit	Installation Unit Cost	ESC Quantity	ESC Cost
1	Mobilization	MB	LS	\$5,500.0		\$ 5,500.00
2	SCM Maintenance	SM	LS	\$6,000.00		\$ 6,000.00

Total Cost of Control Measures

\$ 11,500.00

Appendix H–Erosion and Sediment Control Permit Plan Template

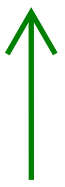

NORTH

Control Measures Legend:	
Concrete Washout Area	(CWA)
Grout Mixing Station	(GMS)
Stabilized Staging Area	(SSA)
Street Sweeping	(SS)
Stockpile	(SP)
Landscaping	(LS)
Seed & Mulch	(SM)
Sediment Control Log	(SCL)
Silt Fence	(SF)
Vehicle Tracking Control	(VTC)

Image by ArapaMAP

Arapahoe County CASE No.:
 Site Address:
 Arapahoe County
 Lot area: x.xx acres
 Disturbance area: x.xx acres

THIS PLAN IS ONLY FOR LAND DISTURBANCES LESS THAN (1) ACRE AND NOT PART OF A LARGER COMMON PLAN OF DEVELOPMENT OR SALE. DISTURBANCES (1) ACRE OR GREATER OR PART OF A LARGER COMMON PLAN OF DEVELOPMENT OR SALE WILL RESULT IN ADDITIONAL REQUIREMENTS.
 Control Measures (CM) pertain to erosion and sediment control are approximate in size and location. This erosion and sediment control plan is not to be utilized as a grading plan. If grading on site is necessary, it shall not adversely impact adjacent properties. Flow arrows may not depict actual flow patterns in the field.
 Proposed structures and improvements shown are approximate in size and location.
 Reference Arapahoe County GESC Manual Standard Notes & Details, current revision. Erosion and Sediment Control (ESC) Permit notes are indicated in italics.

**ARAPAHOE COUNTY
 ACCEPTANCE BLOCK**
 THIS PLAN HAS BEEN REVIEWED BY ARAPAHOE
 COUNTY FOR EROSION AND SEDIMENT
 CONTROL IMPROVEMENTS ONLY

Appendix I–Low Risk Guidance

Low Risk Guidance for Construction Activities (2019, Revised 2025)



ARAPAHOE COUNTY

INTRODUCTION AND BACKGROUND

The purpose of this guidance is to document Arapahoe County’s (County’s) approach to construction activities that do not have the potential to adversely impact drainage patterns or drainageways. This classification of activities has been designated as “low risk”. Low risk discharges are associated with construction activities that have the lowest potential risk to water quality. The majority of low risk activities have a small footprint; are short in duration; not complex in matters of access, grading, excavation and fill; and do not include any significant amount of waste material generation. These projects lend themselves to self-regulation with a Fact Sheet explaining how to minimize or prevent the discharge of pollutants to the County’s Municipal Storm Sewer System (MS4) and state waters.

For construction activities characterized as low risk, the County will take an outreach and compliance assistance approach rather than a permit and inspection approach. An outreach approach encourages the owner to participate in the responsibility for environmental stewardship. The County has determined that it has a significant physical presence in unincorporated Arapahoe County to provide sufficient oversight to verify this approach to water quality protection.

At any time, a low risk activity can be upgraded to require a Grading, Erosion, and Sediment Control (GESC) permit when conditions indicate the land disturbance activity must be managed with a formalized inspection effort to prevent sediment or pollutants from leaving the site and impacting the MS4. This formalized permitting process is further discussed in the County *GESC Manual*, available on the County’s website. Non-stormwater discharges to the MS4 from low risk construction activities may be enforced upon using the County’s Illicit Discharge, Detection and Elimination (IDDE) program.

LOW RISK DESIGNATION CRITERIA

The GESC program and its designation of low risk construction activities eliminates the process of obtaining a permit and the review and inspection necessary to document adherence to a GESC permit. The low risk designation offers minimal or no risk to drainage patterns, the drainageway, or sedimentation of the stormwater system. Since this is a no-permit approach and no contact is required with the County to obtain a permit, identification of project locations for visual observance of activities will be from various methods, including customer service calls, contractor general inquiries, Public Improvement Construction Permits, Street Cut Right-of-Way Permits, and general observations by County staff as they’re in the field constructing projects and performing maintenance activities.

Criteria

In order to qualify under this Low Risk Guidance for Construction Activities, the following criteria must be met:

1. The construction activity results in a land disturbance of less than 1 acre, not part of a larger common plan of development or sale that would disturb 1 acre or more.
2. The construction activity does not result in a post-construction water quality requirement, as outlined in the County Stormwater Management Manual, available at the County’s web site.
3. The discharge associated with the construction activity is composed only of stormwater.
4. The discharge associated with the construction activity must be visibly clear and not contain floating or solid materials.

5. The construction activity does not result in an impact to the floodplain and does not require a No-Impact Floodplain Development Permit.
6. The construction activity is not expected to contribute sediment to the stormwater system and has a very low potential of causing a water quality impact or a violation of a water quality standard.
7. The construction activity produces negligible soil loss or movement.
8. The construction activity complies with the lawful requirements of federal agencies, municipalities, counties, drainage districts, ditch owners, and other local agencies regarding any discharges to storm drain systems, conveyances, ditches or other water courses under their jurisdiction.
9. The construction activity does not result in flooding of neighboring property, streets, gutters or storm sewers.
10. The construction activity does not result in adverse impacts on adjacent properties.
11. Access for inspections can occur from the right-of-way.
12. The construction activity does not adversely impact drainage patterns.

The County has created Low Risk Fact Sheets available on the County's website for use by the contractor or property owner for the following construction activities that meet the low risk designation criteria discussed above, as follows:

Residential Construction

These activities include, but are not limited to, landscaping, house additions, house remodeling, garage additions, and accessory building construction.

Utility and Right-of-Way Construction

Utility activities include, but are not limited to, utility boring, water main taps, manhole rehabilitation, potholing, pipe removal and replacement, pipe maintenance, drilling operations, testing and monitoring, streetscaping, and pipe relining. Boring projects greater than 1,000 linear feet may require other local permits. The installation and maintenance of utility lines outside of the Southeast Metro Stormwater Authority (SEMSWA) service area in excess of 1,000 linear feet open cut and trench requires a GESC Permit. Routine maintenance of utilities within the public right-of-way requires an Annual Utility Maintenance Permit from the County.

Minor Commercial Construction

These activities include, but are not limited to, generation pads, parking lot maintenance, demolition, building remodel, building addition, cell tower construction, and residential solar panel installation.

Park, Metro District, and Homeowners Association Construction

These activities include, but are not limited to, trail installation and maintenance, structure installation and maintenance, and post-construction control measure maintenance and repair.

GENERAL CONSIDERATIONS FOR LOW RISK CONSTRUCTION ACTIVITIES

Control measures should be implemented as necessary to meet the conditions above, by anyone discharging in accordance with this guidance. Refer to the individual Low Risk Fact Sheets for specific activities.

Definitions

Common Plan of Development or Sale: A contiguous area where multiple separate and distinct construction activities may be taking place at different times on different schedules, but remain related. "Contiguous" means construction activities located in close proximity to each other

(within ¼ mile). Construction activities are considered to be “related” if they share the same development plan, builder or contractor, equipment, storage areas, etc.

Construction Activity: Refers to ground surface disturbing and associated activities (land disturbance), which include, but are not limited to, clearing, grading, excavation, demolition, installation of new or improved haul roads and access roads, staging areas, stockpiling of fill materials, and borrow areas. Construction does not include routine maintenance to maintain the original line and grade, hydraulic capacity, or original purpose of the facility. Activities to conduct repairs that are not part of routine maintenance or for replacement are construction activities and are not routine maintenance. Repaving activities where underlying and/or surrounding soil is exposed as part of the repaving operation are considered construction activities. Construction activity is from initial groundbreaking to final stabilization regardless of ownership of the construction activities.

Control Measure: Any best management practice or other method used to prevent or reduce the discharge of pollutants to state waters. Control measures include, but are not limited to best management practices. Control measures can include other methods such as the installation, operation, and maintenance of structure controls and treatment devices.

Good Engineering, Hydrologic and Pollution Control Practices: Methods, procedures, and practices that:

- Are based on basic scientific fact(s).
- Reflect best industry practices and standards.
- Are appropriate for the conditions and pollutant sources.
- Provide appropriate solutions to meet the associated permit requirements, including practice-based and numeric effluent limits.

Illicit Discharge: Any discharges to an MS4 that is not composed entirely of stormwater except discharges specifically authorized by a CDPS or NPDES permit and discharges resulting from emergency firefighting activities, or otherwise in conformance with the County’s MS4 permit.

Land Disturbing Activity: Any activity that results in a change in the existing land surface (both vegetative and non-vegetative). Land disturbing activities include, but are not limited to clearing, grading, excavation, demolition, installation of new or improved haul roads and access roads, staging areas, stockpiling of fill materials, and borrow areas. Compaction that is associated with stabilization of structures and road construction shall also be considered a land disturbing activity. In the Cherry Creek Basin, a land disturbance means a human-made change in the natural cover or topography of the land, including grading, cutting and filling, building, paving, excavating and any other activities that may result in or contribute to soil erosion or sedimentation in state waters or the discharge of pollutants, except individual home construction.

Municipal Separate Storm Sewer System (MS4): State, city, town or other public entity-owned conveyance or system of conveyances (including roads with drainage systems, municipal streets, catch basins, curbs, gutters, ditches, human-made channels, or storm drains) designed to collect or convey stormwater.

Pollutant: Dredged spoil, dirt, slurry, solid waste, incinerator residue, sewage, sewage sludge, garbage, trash, chemical waste, biological nutrient, biological material, radioactive material, heat, wrecked or discarded equipment, rock, sand, or any industrial, municipal or agricultural waste. See 5 CCR 1002-61.2(76).

State Waters: Any and all surface waters and subsurface waters which are contained in or flow in or through this state, but does not include waters in sewage systems, waters in treatment works of disposal systems, waters in potable water distribution systems, and all water withdrawn for use until use and treatment have been completed. This definition can include water courses that are usually dry.

Stormwater: Stormwater runoff, snow melt runoff, and surface runoff and drainage. See 5 CCR 1002-61.2(103).

Water Quality Standards: Any standard promulgated pursuant to section 25-8-204 C.R.S. For purposes of this permit, water quality standards are a narrative and/or numeric restriction established by the Water Quality Commission applied to state surface waters to protect one or more beneficial uses of such waters. Whenever only numeric or only narrative standards are intended, the wording shall specifically designate which is intended. See 5 CCR 1002- 31.5(37).

Appendix J–Hold Harmless Letter for Early Start of Grading

HOLD HARMLESS LETTER FOR EARLY START OF GRADING

Engineering Program Manager
Arapahoe County
6924 South Lima Street
Centennial, Colorado 80112

Subject: Early Start (Grading Only) for:

Case No: _____

We are requesting an early start on implementing the Grading, Erosion and Sediment Control (GESC) or Erosion and Sediment Control (ESC) Plan(s) for the project. The construction drawings, phase III drainage report, and/or other technical documents have not yet been approved by Arapahoe County (County). In order to start this work, we understand that the GESC or ESC Plan must be approved by the County, GESC or ESC Permit issued by the County, and the collateral posted. We agree that no impervious area will be created at the site as part of this early grading approval.

We further understand that any work that occurs under this Hold Harmless Letter for Early Start of Grading will be at the risk of the permittee. Specifically, any changes required for the GESC or ESC Plan(s) or GESC or ESC Permit resulting from the approved construction drawings, or other applicable documents, will be the responsibility of the owner. We acknowledge that the County will not be held responsible for those changes or the cost of those changes. We shall be responsible for all the costs associated with any changes that may be required under the GESC or ESC Plan(s) and permit. The County shall not be responsible for any costs.

I understand that the owner assumes all of the risk of completing grading prior to approval of development plans for a site. Approval of the GESC or ESC plan(s) does not imply approval of other engineering concepts or documents associated with a submittal.

Sincerely,

(Owner's Name, Title, and Signature)

Date: _____

(Operator's Name, Title, and Signature)

Date: _____

*Note that the Owner and Operator are co-permittees on the GESC or ESC permit.

For Internal Use Only

- County Case Engineer Approval
- Engineering Services Division Manager Approval

Appendix K—Single-Family Residential Lot Erosion Control Certificate

Single-Family Residential Lot Erosion Control Certificate

(Submitted by GESC Permittee prior to issuance of Certificate of Occupancy)

Date: _____

Builder: _____ Building Permit #: _____

Property Address: _____

Subdivision: _____ Lot: _____ Block: _____

I hereby certify that:

All minimum drainage, erosion, and sediment control requirements set forth by Arapahoe County Zoning Resolution have been adhered to, including the following:

- Adequate drainage away from the structure(s) and off the lot has been established and verified on the Drainage Certificate.
- The purchaser has been informed of the need to maintain established drainage patterns as shown on the Drainage Certificate.
- Permanent erosion controls or adequate temporary erosion and sediment control measures designed to be effective for 90 days have been properly implemented on this lot.

I shall cause the purchaser to be aware of the need for regular inspection and maintenance of the temporary erosion and sediment control measures implemented and the need for timely installation of permanent measures, all to prevent drainage, erosion, and sedimentation problems.

Signed: _____ Print: _____ Date: _____

(GESC Permittee)

Signed: _____ Print: _____ Date: _____

(GESC Manager)

