

# SOUTH METRO FIRE RESCUE FIRE MARSHAL'S OFFICE



Bill Skinner, AICP, Senior Planner  
Arapahoe County Public Works – Planning Division  
6924 S. Lima St, Centennial CO 80112  
720-874-6651  
bskinner@arapahoegov.com

Project Name: Dove Valley Warehouse 8001 S Chambers  
Project File #: **ASP22-002**  
S Metro Review # REFSP22-00130

Review date: July 12, 2022

Plan reviewer: Jeff Sceili  
720-989-2244  
[Jeff.Sceili@Southmetro.org](mailto:Jeff.Sceili@Southmetro.org)

**Project Summary:** Construction of a 103k square foot warehouse/office space

Code Reference: 2021 Fire Code Edition, 2021 Building Code Edition

South Metro Fire Rescue (SMFR) has reviewed the above project and has conditionally approved the plans based on the following comments that must be resolved prior issuance of any permits. Applicants and Contractors are encouraged to contact SMFR regarding the applicable permit requirements for the proposed project.

### Fire Flow per Appendix B

Construction Type	Building Area (SF)	Fire Flow (GPM)	Sprinkler System (Type)	Reduced Fire Flow
<b>IIB</b>	103,000	6750	13	3375

# **SOUTH METRO FIRE RESCUE**

## **FIRE MARSHAL'S OFFICE**



## **FIRE ACCESS ROAD DESIGN CRITERIA**



BUILDING exterior walls (and any portion thereof) of any buildings that are more than 150 feet from the curb line of a public street shall be served by a Fire Apparatus Access Road which shall be unobstructed. This distance is measured by an approved route around the exterior of the building or facility. Additional allowances may be made for some sprinkler protected structures. Alternate access arrangements may be accepted based on site conditions and building fire protection features.

Due to the possibility of heavy vehicle traffic, residential and commercial collector and arterial roads may not be considered adequate for fire suppression operations; no credit for access to perimeter of buildings shall be given from collectors or arterials, unless specifically approved.

Sites not be capable of meeting these requirements and any alternative means must be evaluated and approved by the Fire Marshal.

FIRE APPARATUS ACCESS ROADS shall be of an all-weather surface capable of supporting the imposed loads of fire apparatus. Maximum grade on site shall not exceed six percent (6%). Roads shall be asphalt or concrete. Other surfaces may be accepted on a case by case basis.

The minimum unobstructed width of the fire apparatus access road shall be 20 feet. In order to maintain the minimum width and prevent obstructions such as parking of vehicles fire lane signs shall be installed in an approved manner. A minimum vertical clearance of 13 feet, 6 inches shall be maintained for the entire required width of the access road.

Any dead-end access road over 150 feet long shall be provided with an approved turnaround that may be a circle, tee, hammerhead, or other functional approved design.

# SOUTH METRO FIRE RESCUE FIRE MARSHAL'S OFFICE



VEHICLE SPECIFICATIONS are provided for the largest apparatus in use by South Metro Fire Rescue. Fire Apparatus Access Roads shall be capable of accommodating this apparatus.

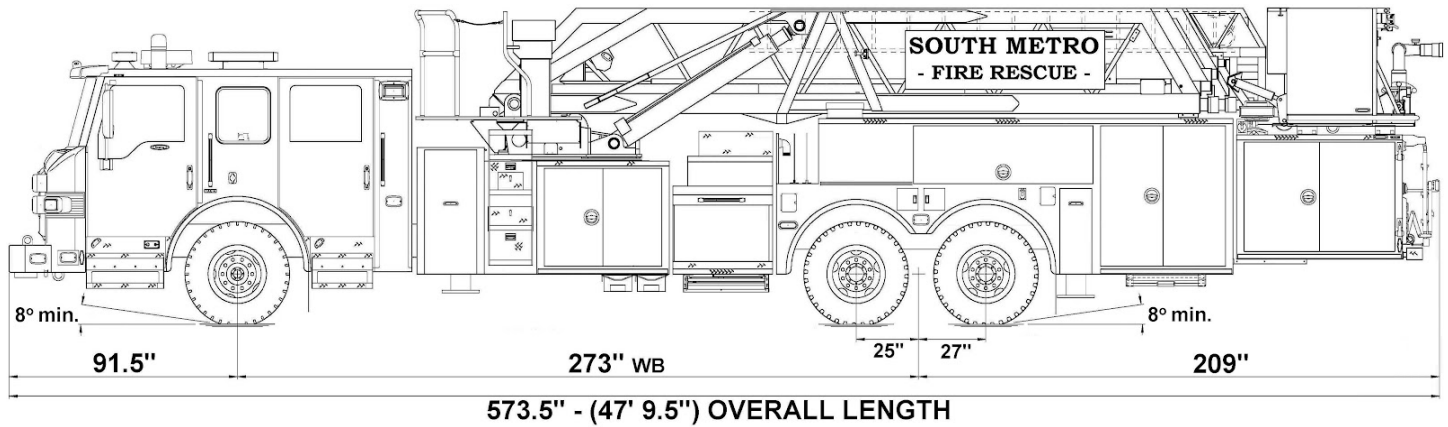

# SOUTH METRO FIRE RESCUE FIRE MARSHAL'S OFFICE

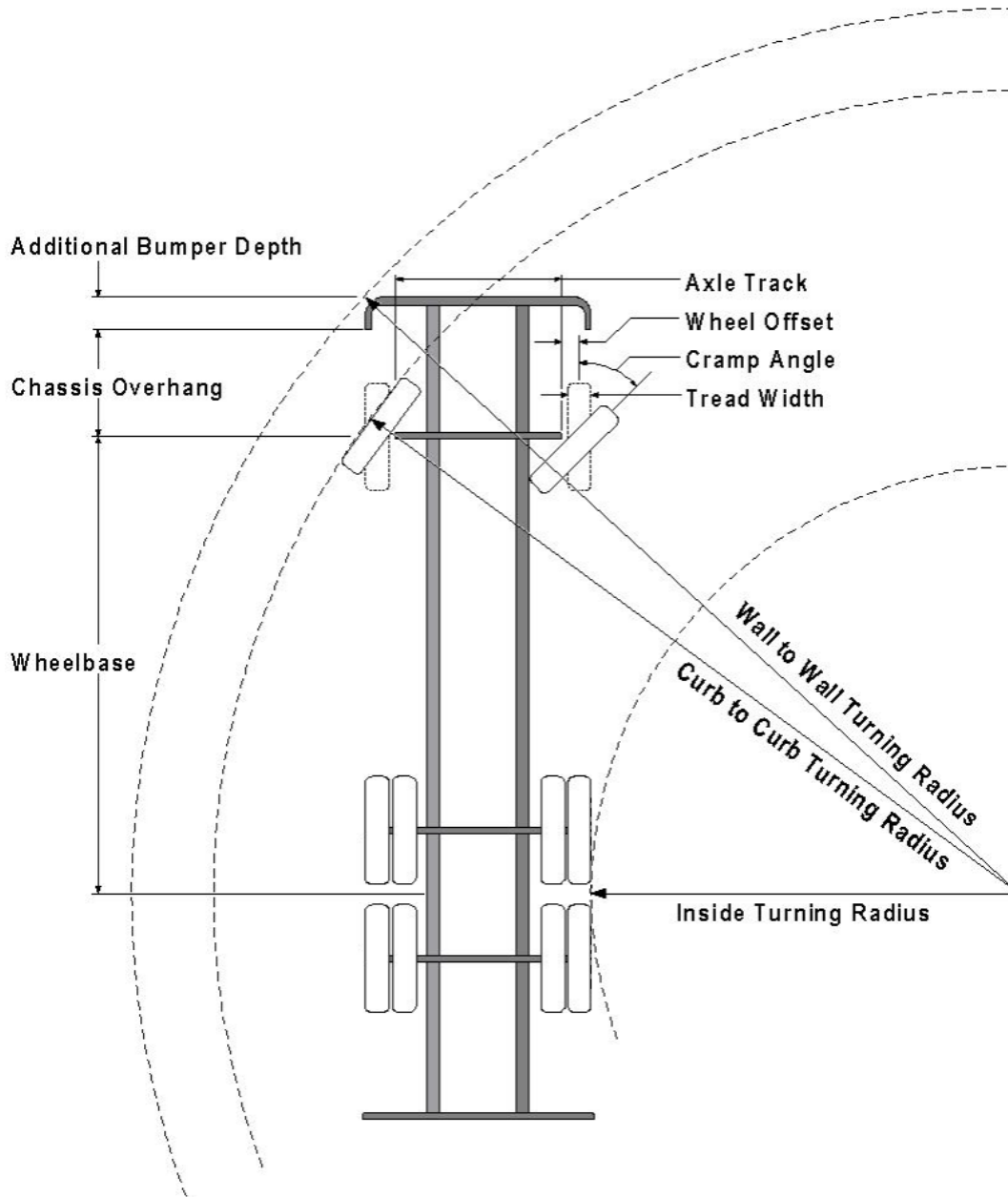

## Vehicle Specifications

Length: 47' 9.5"

Width: 8' 5" - (10' 1" mirror to mirror)

Height: 10' 9"

Wheelbase: 273 in.

# **SOUTH METRO FIRE RESCUE FIRE MARSHAL'S OFFICE**

---



Design load: 80,000 pounds

Inside Cramp Angle: 40°

Axle Track: 83"

Wheel Offset: 5.3"

Tread Width: 13.5"

## **Turning Radii:**

Inside Turn: 26 ft. 1 in.

Curb to curb: 41 ft. 11 in.

Wall to wall: 46 ft. 8 in.

**Where objects are present adjacent to the fire apparatus access road, particularly on turns and turn arounds which require backing, a reasonable safety margin shall be provided to prevent potential damage to the property and to the fire apparatus.**

PRIVATE ROADS that provide access to more than two dwellings or one or more commercial buildings shall be constructed to meet the roadway standards approved by the South Metro Fire Rescue Authority for fire apparatus access. Private roads that do not meet the roadway standard may be accepted provided that alternative methods and materials are incorporated into the subdivision that address the fire and life safety of the citizens.